

ALTRONIC®, INC.
712 TRUMBULL AVENUE
GIRARD, OHIO 44420

ALTRONIC II-CPU IGNITION SYSTEM
DC POWERED, "D" SERIES

INSTALLATION INSTRUCTIONS
FORM DC-CPU II 6-88

WARNING: AN IMPROPERLY INSTALLED OR OPERATING IGNITION SYSTEM MAY LEAD TO IMPROPER ENGINE OPERATION WHICH CONSEQUENTLY COULD POSE THE THREAT OF PERSONAL INJURY TO OPERATORS OR OTHER NEARBY PERSONNEL.

1.0 DESCRIPTION

- 1.1 The Altronic II-CPU, DC-powered ignition system is a microcircuit-based, capacitor discharge system applicable to slow and medium speed, high BMEP engines. The system features crankshaft-triggered timing accuracy and the capability to vary timing electronically by several means, including an external 4-20 ma. control signal. There are no wearing rotating parts added to the engine in the DC-powered CPU system. The system consists of a specially-designed DC power converter unit (see section 13.1), a CPU control unit, a wiring harness, (2) magnetic pick-ups and cables, a Hall-effect pick-up and trigger magnet (4-cycle engines only), and an ignition coil for each spark plug; see drawing 209 060A for a total system overview.
- 1.2 For non-hazardous operations there is an unshielded epoxy coil 291 001. For hazardous area operations, shielded primary cable assemblies are available for connection to one of two optional shielded coil series - 291 001-S or 591 008. NOTE: Use only the above Altronic coils with the Altronic II-CPU ignition system.

2.0 MOUNTING THE 24VDC CONVERTER UNIT

- 2.1 Select a mounting location meeting the following requirements:
 - Located within 12 ft. of the CPU unit; the converter may be located on or off the engine.
 - The front panel door of the converter unit should be easily accessible and free to swing open.
 - Select a location where the maximum ambient temperature does not exceed 150°F. (65°C.).
- 2.2 The converter unit should be fastened securely to a rigid bracket using the shock mounts provided.

3.0 MOUNTING THE ALTRONIC II-CPU CONTROL UNIT

- 3.1 Select a mounting location meeting the following requirements (refer to drawing 209 060A):
 - Located within 12 ft. of the 24 VDC converter unit.
 - Located within 7 ft. of the primary junction box.
 - The front panel door of the control unit should be easily accessible and free to swing open.
 - Select a location where the maximum ambient temperature does not exceed 150°F. (65°C.).
- 3.2 The control box should be fastened securely to a rigid engine bracket using the shock mounts provided.

4.0 MOUNTING FLYWHEEL GEAR / DRILLING FLYWHEEL HOLES

4.1 The Altronic II-CPU system requires a source of angular position pulses from the engine crankshaft. This can be a flywheel ring gear, a separately provided gear or specially drilled holes in the flywheel. The source of position pulses must meet the following requirements:

- Must be ferrous material
- Diameter of 18" or greater
- No. of teeth or holes of 180 or greater
- Maximum runout referenced to the pick-up of .007"

Refer to drawings 209 060A, 209 102 and 209 103 for further details.

5.0 MOUNTING THE MAGNETIC PICK-UPS

5.1 The system requires two magnetic pick-up signals: the angular position pulses from the gear or drilled holes and a reset pulse near the most advanced firing position desired for no. 1 cylinder. The pick-ups must be mounted to rigid brackets to maintain an air gap of $.015" \pm .005"$ with respect to the rotating gear or flywheel. It is also important for maximum signal efficiency that the centerline of the pick-up pass through the center of the rotating part - see drawing 209 102.

6.0 MOUNTING THE FLYWHEEL RESET PIN

6.1 Set the engine with no. 1 cylinder six (6) degrees ahead of the most advanced firing point. Mark a point on the flywheel directly opposite the pole piece of the reset magnetic pick-up; then rotate the engine to a position convenient for drilling and tapping the flywheel at the point marked above. The reset pin should be made from a steel (magnetic) 1/4"-20 bolt or stud. See drawing 209 102 for details.

6.2 Rotate the engine to the original set point and adjust the air gap between the end of the reset pin and the magnetic pick-up at .010" using a feeler gauge.

7.0 MOUNTING THE CYCLE TRIGGER (4-CYCLE ENGINE ONLY)

7.1 The trigger magnet 720 002 must be mounted on the engine camshaft or other accessory drive operating at camshaft speed. An 8mm tapped hole 1/2" (12.7mm) deep is required - see drawing 720 002 for details. The magnet MUST rotate on a diameter NOT EXCEEDING 6 inches (150mm).

7.2 Set the engine on the COMPRESSION stroke of no. 1 cylinder with the reset pin DIRECTLY OPPOSITE the reset pick-up. The Hall-effect pick-up (591 014-2) must be mounted DIRECTLY OPPOSITE the trigger magnet (720 002) coincident with the reset pick-up and pin being lined-up - refer to drawing 209 060A.

NOTE: The Hall-effect signal and the reset pick-up signal must occur at the same time for the system to function.

The Hall-effect pick-up dimensions are shown on drawing 591 014.

7.3 The air gap between the Hall-effect pick-up and trigger magnet must not exceed .040" (1.0mm).

8.0 24VDC CONVERTER UNIT WIRING

- 8.1 It is necessary to fabricate two wiring conduits; use 1/2" conduit (rigid or flexible) for mechanical and shock-hazard protection:
- RIGHT-HAND ENTRY - Two leads from a source (preferably non-interruptible) of 20-28 VDC (nominal 24 VDC), 2 amps minimum. The negative of the 24 VDC supply MUST be common with engine ground.
 - LEFT-HAND ENTRY - Two leads leading from the converter unit to the Altronic II-CPU control unit - see drawing 209 061A for details.
- CAUTION: These leads carry 400 VDC and are a shock hazard. Do not handle these wires while the system is powered.**
- 8.2 Provision must be made to interrupt the 24 VDC supply to stop the ignition system output. Use a switch rated for 24 VDC, 10 amps; refer to drawing 209 060A.

9.0 CPU CONTROL UNIT WIRING

- 9.1 RIGHT-HAND ENTRY - A conduit containing the two 400 VDC output leads from the 24 VDC converter unit must be run to the right-hand entry in the bottom access plate of the CPU control unit. Connect as shown on drawing 209 061A. The entry hole is sized for a 1/2"-14 NPT male conduit fitting.
- 9.2 CENTER ENTRY - Run a separate conduit for the two (2) magnetic pick-up cable assemblies. These should enter through the center entry in the CPU box and terminate as shown on drawing 209 061A. The entry hole is sized for a 1/2"-14 NPT male conduit fitting. 4-CYCLE ENGINE ONLY: The cable from the Hall-effect pick-up also enters through the center hole and connects as shown on drawing 209 061A.
- 9.3 LEFT-HAND ENTRY - A separate conduit must be used to the left-hand entry for all connections to the left-hand, 12-position terminal strip in the CPU box. Use 24AWG, UL style 1015 wire for all these connections; this wire is available from Altronic under part no. 603 102 (black) or 603 103 (white).
- A. Terminals 1-4 are used for the 4-20 ma timing control connections. The 4-20 ma loop connects to terminals 1 and 2; the 12-24 VDC supply voltage is connected to terminals 3 and 4. See drawings 209 104B and 209 110. NOTE: Terminals 2 and 4 MUST BE common negative supply.
 - B. Terminals 5 and 6 are used for the one-step timing adjustment if used; see drawings 209 061A and 209 109.
 - C. If used, the fault output leads connect to terminals 10 and 11; see drawing 209 111 and section 14.2 for details.

10.0 PRIMARY WIRING (REFER TO WIRING DIAGRAMS 209 105A/209 106A)

10.1 The main wiring harness (293 023-X, 293 026-X, or 293 027-X) connects the CPU control unit to the engine junction box. Refer to drawing 509 025 if it is desired to shorten the conduit length of the harness. Insert the connector into the Altronic II-CPU control unit and tighten hand tight; then carefully tighten an additional one-sixth turn with a wrench.

10.2 Write in the engine firing order below the applicable CPU control unit:

281 508-X A - B - C - D - E - F - G - H
ENGINE: - - - - -

281 512-X A - B - C - D - E - F - G - H - J - K - L - M
ENGINE: - - - - -

281 516-X A - B - C - D - E - F - G - H - J - K - L - M - R - S - T - U
ENGINE: - - - - -

281 520-X A1-A2-B1-B2-C1-C2-D1-D2-E1-E2-F1-F2-G1-G2-H1-H2-J1-J2-K1-K2
ENGINE: - - - - -

10.3 Connect the harness leads in the junction box in accordance with the engine's firing order. The leads from the junction box corresponding to the above system outputs connect to the ignition coil negative (-) terminals. The "P" lead and the common coil ground lead(s) connecting the positive (+) terminals of the ignition coils must be grounded to the engine in the junction box. On V-engines, run a separate common ground lead for each bank. All primary wiring should be protected from physical damage and vibration. Refer to wiring diagrams 209 105A (unshielded) or 209 106A (shielded) for general details.

10.4 Primary wire should be no. 16 gauge stranded, tinned copper wire. The insulation should have a minimum thickness of .016" and be rated 105°C. or higher. Irradiated PVC or polyolefin insulations are recommended. Altronic primary wire no. 503 188 meets these specifications.

10.5 If two ignition coils per cylinder connected to a common output are used, use parallel wiring as shown on the wiring diagrams 209 105A and 209 106A.

11.0 SHUTDOWN WIRING

11.1 To shut-off the DC powered ignition system, the 24 VDC supply to the converter unit must be interrupted. Use a switch rated 24 VDC, 5 amps. Refer to drawing 209 060A for details.

11.2 DO NOT ground leads "N" or "V" to stop the ignition with a DC power source. This can cause component failure in the DC converter and/or the CPU control unit.

12.0 SECONDARY WIRING

- 12.1 Mount the ignition coils as close as possible to the engine spark plugs consistent with a secure mounting and avoidance of temperatures in excess of 185°F.
- 12.2 The spark plug leads should be fabricated from 7mm, silicone insulated, tinned copper conductor with suitable terminals and a silicone spark plug boot. Keep spark plug leads as short as possible and in all cases not longer than 18 inches. Spark plug leads should be kept at least 2 inches away from any grounded engine part. In deep spark plug wells, use rigid, insulated extenders projecting out of the well.
- 12.3 The use of a clear, silicone grease (such as Dow Corning DC-200) is recommended for all high-tension connections and boots. This material helps seal out moisture and prevent corrosion from atmospheric sources.

13.0 OPERATION (Refer to drawing 209 107A)

- 13.1 The 24 VDC converter provides the power for the basic system operation. The Altronic converter is a special design that outputs a regulated 400 VDC to the energy storage capacitors and contains special circuitry limiting the output after each firing to insure proper SCR turn-off.

NOTE: During each start-up, it is necessary to turn off the 24 VDC power to the converter unit. Re-apply power approximately four seconds prior to the point in the engine start-up sequence when ignition is desired.

On 4-cycle engines, a Hall-effect pick-up senses a trigger magnet mounted on the engine camshaft to determine whether the flywheel is on the compression or exhaust stroke.

- 13.2 The CPU Control Unit consists of power conditioning circuitry for the logic circuit and memory, and an electronic distribution circuit. The system operates with two magnetic pick-up inputs. One counts the teeth on a crankshaft-mounted gear or holes drilled in the flywheel; the other provides a reset pulse once per engine revolution. Two counts are provided for each gear tooth or flywheel hole. Thus the degree separation from one count to the next is $360/2N$, where N = no. of teeth or holes. This value is called a TOOTH DEGREE.

Examples: No. of teeth = 180
TOOTH DEGREE = $360/2 \times 180 = 1.0$ engine degree
No. of teeth = 230
TOOTH DEGREE = $360/2 \times 230 = 0.78$ engine degree

The TOOTH DEGREE is the basic unit of timing adjustability or change in the system. As ignition timing is varied on an operating engine, it will vary one TOOTH DEGREE at a time; no finer increment is possible. Therefore, a minimum of 180 interruptions (teeth or holes) is recommended.

13.3 All timing adjustments are made by delaying (retarding) the spark output a given number of TOOTH DEGREES. There are three ways to vary ignition timing with the DC-CPU system; all are through connections and/or switches in the CPU control unit (refer to drawing 209 108A):

- MANUAL SETTING (SW1) - This subtracts TOOTH DEGREES (0-15) from the reset pin position to determine the maximum advance timing point in operation.
- ONE-STEP SETTING (SW2) - This sets another retard amount in TOOTH DEGREES (0-15) that can be switched in through the use of external contacts (see drawing 209 109).
- 4-20 MA ADJUSTMENT (SW3) - Open position allows influence of the 4-20 ma. control loop signal; closed position deletes any effect from the loop signal. The system reads "4 ma." as no retard, "20 ma." as full retard and is linear in between. The standard ranges of the system are 24 engine degrees (code C), 36 engine degrees (code B) and 48 engine degrees (code A); the timing range code is the last letter in the Memory Code Part No. - see section 13.4. Drawing 209 110 shows the timing curve vs. milliamp (ma.) signal input and the wiring hook-up.

13.4 The system memory chip contains the specific information for any particular engine application. This includes no. of cylinders, 2 or 4-cycle, engine firing pattern in degrees, no. of teeth or holes being sensed, and timing range on the 4-20 ma. loop control. The Memory Code Part No. is written on the large memory integrated circuit chip in the CPU Control Unit. See form AII-CPU AL for the Memory Code Part No. to be sure the system program meets the application requirements. To order a spare memory chip, order part no. 601 507 (memory code).

14.0 INDICATION OF CURRENT LOOP OPERATION

14.1 The logic board on the cover of the CPU control unit has a LED indicator light for current loop operation. The light should be on if the system is on current loop operation; if not, check connections 1 through 4 and the external loop circuits.

14.2 The system also has a normally-closed, solid state fault-output switch available at terminals 10 and 11 in the CPU control unit; this automatically opens if the 4-20 ma. control loop or the loop power supply is lost. The internal switch has a rating of 30 VDC, 250 ma. Terminals 10 and 11 in the CPU control unit may be connected to an external alarm or shutdown device; a typical hook-up using a relay is shown on drawing 209 111.

NOTE: Terminal 11 must be the negative supply; it is electrically common with terminals 2 and 4 - see drawing 209 111.

15.0 TROUBLESHOOTING GUIDE

PROBLEM	TEST PROCEDURE	TEST RESULT	CORRECTIVE ACTION
Ignition not firing on any cylinder.	Measure voltage at CPU unit "N" pin.	Below 30 VDC	See checklist #1
		30-150 VDC	Check cranking RPM
		Above 150 VDC	See checklist #2
Ignition mis-firing on one cylinder only	Check primary with oscilloscope or timing light	Primary firing	Check spark plug, coil or plug lead.
		No primary firing	See checklist #3
Ignition timing steady but incorrect	Check timing on several cylinders on each bank	All incorrect by same amount	See checklist #4
		Incorrect by varying amounts	See checklist #5
Ignition timing varies	Put SW3 in closed position	Timing OK	4-20 ma signal is problem
		Timing still varies	Check gap and alignment of gear-tooth (or hole) pick-up

Checklist #1

1. Disconnect the primary harness. If voltage is now OK, problem is the CPU control unit (distributor board).
2. If voltage is still low with harness disconnected, unplug the 6-position plug (right side) inside the CPU control unit. Measure voltage at the 6-position connector: (+) to "A" pin, (-) to "B" pin; if voltage OK, problem is the CPU control unit (distributor board).
3. If voltage is still low, problem is in the DC converter unit.

Checklist #2

1. Check primary ground connections and coil grounds.
2. Check air gap (.015") and alignment vs. interrupting element on both magnetic pick-ups.
3. Check continuity of magnetic pick-up connections. Unplug the 5-position plug (middle) inside the CPU control unit. Measure resistance across the two pairs of magnetic pick-up leads; 1,100 ohms is the correct reading.
4. On 4-cycle engines, check that the Hall-effect pick-up and its triggering magnet are exactly lined-up when the reset pin exactly lines up with the reset magnetic pick-up on the compression stroke of no. 1 cylinder.
5. If all above checks are OK and system still does not fire, problem is in the CPU control unit.

Checklist #3

1. Check all primary wiring and connections for continuity and/or shorts to ground. NOTE: Do not apply a megger or other high voltage tester without first disconnecting the main harness from the CPU control unit.
2. If above appears OK, problem is most likely in CPU control unit (distributor board).

Checklist #4

1. Attempt to remedy by changing position of manual timing switch SW1 - see drawing 209 108A.
2. If timing still is incorrect, check for proper position of reset pin; see section 6.0.

Checklist #5

1. Check firing order of engine vs. CPU firing order (A-B-C-etc.).
2. Check memory code no. vs. application - see section 13.4.

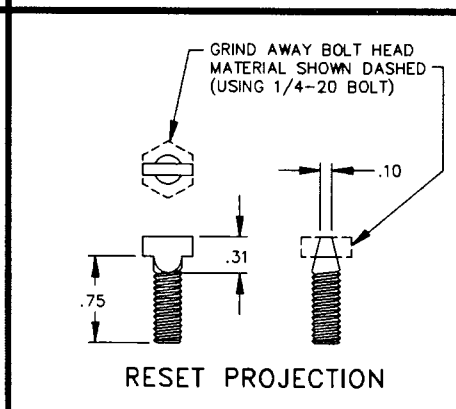
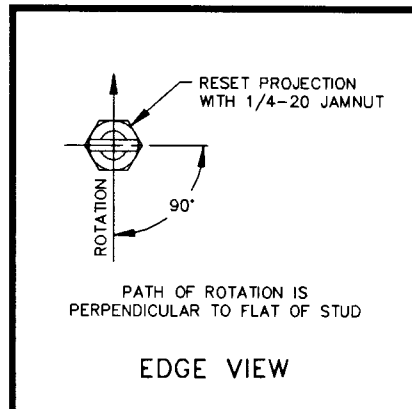
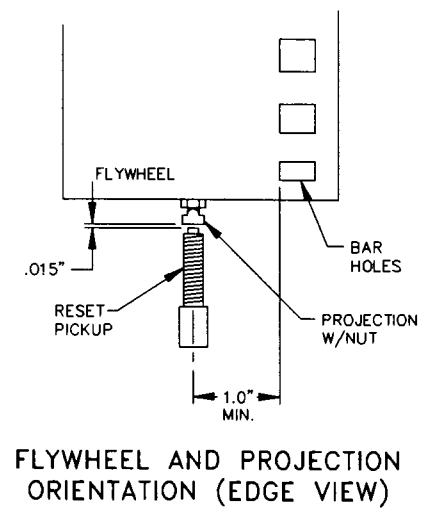
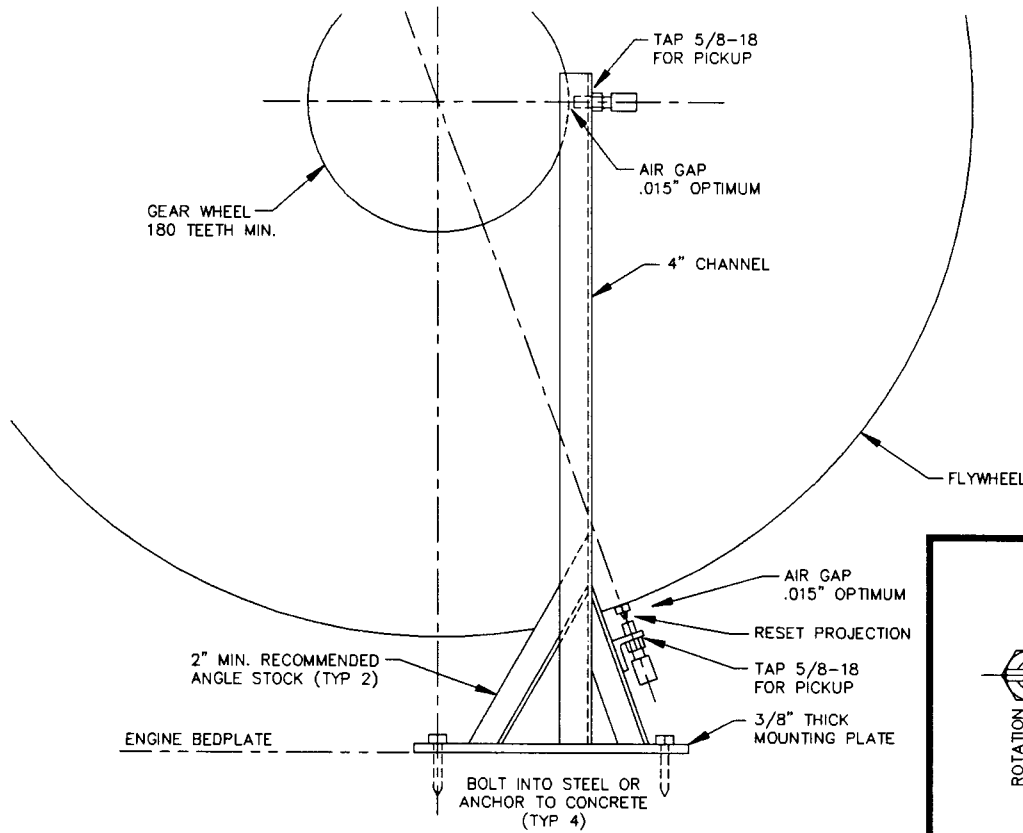

NOTE:
VISUAL PROPORTION OF THIS ILLUSTRATION
WILL CHANGE WITH VARIATIONS IN GEAR AND
FLYWHEEL SIZE AND RELATIONSHIP.

REVISIONS			
NO.	DATE	BY	DESCRIPTION
3	7-18-90	WTP	REDRAWN ON CAD; UPDATED
4			
5			
6			
7			

TOLERANCES (EXCEPT AS NOTED)			
DECIMAL .XXX - ±.005 .XX - ±.010			
FRACTIONAL			
MATERIAL			
ALTRONIC INC.		TITLE PICKUP MOUNTING DETAIL	
DRAWN BY DA	SCALE NONE	PART NUMBER	
CHECKED BY	DATE 11-9-84	209 102	
APPROVED BY			

NOTE: REQUIRED ONLY FOR 4-CYCLE ENGINES

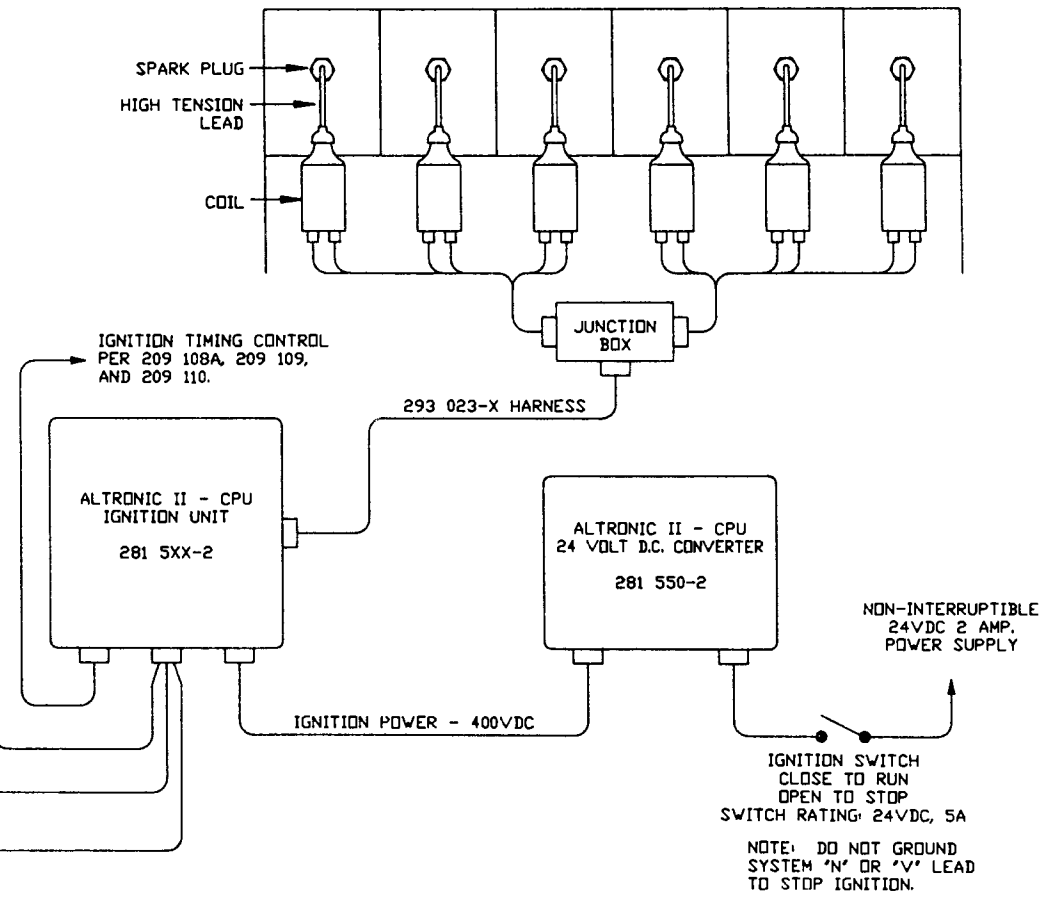
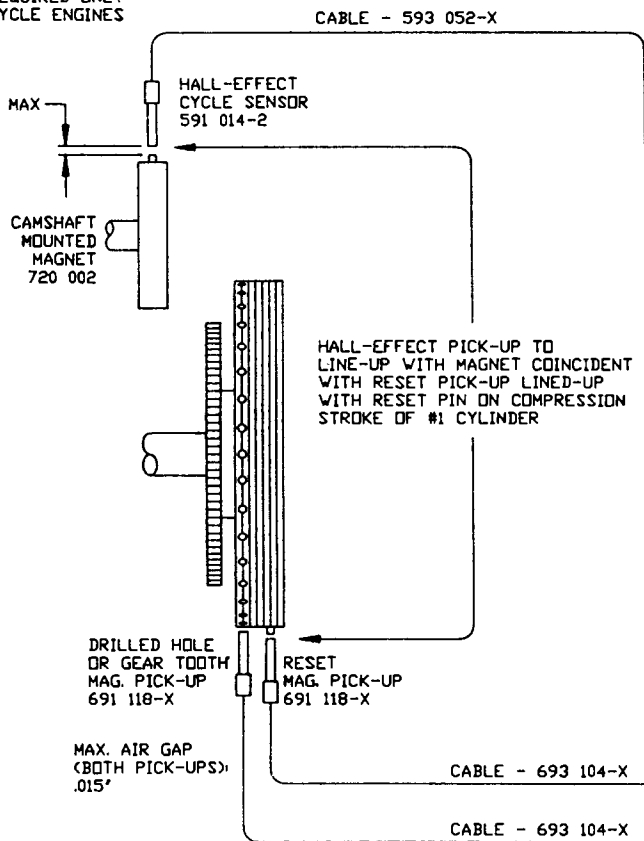

REVISIONS				TOLERANCES (EXCEPT AS NOTED)		ALTRONIC INC.		
NO.	DATE	BY	DESCRIPTION	DECIMAL	FRACTIONAL	TITLE	SCALE	PART NUMBER
1				.XXX - ±.005		DC POWERED ALTRONIC II CPU LAYOUT	NONE	209 060A
2				.XX - ±.010				
3						DRAWN BY	DATE	
4						WTP	6-7-88	
5						CHECKED BY		
						MATERIAL		
						APPROVED BY		

281 5XX-2
CPU II UNIT

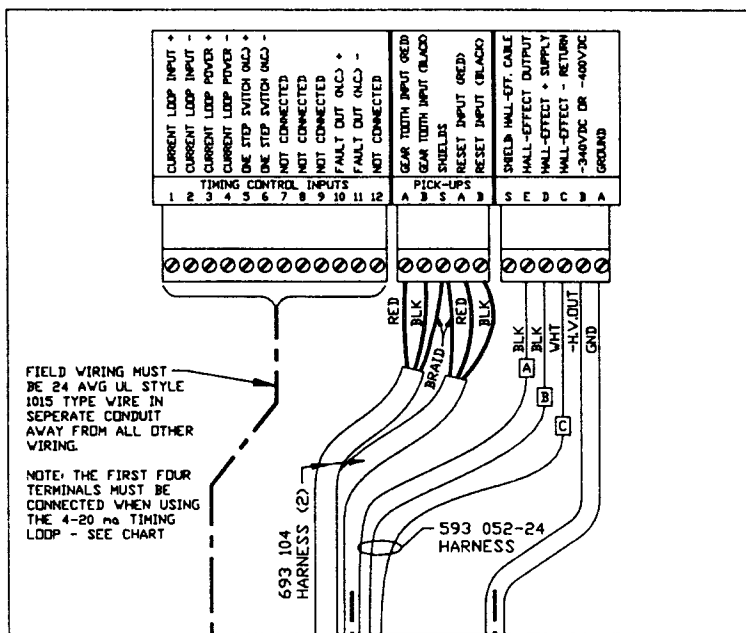

FIELD WIRING MUST BE 24 AVG UL STYLE 1015 TYPE WIRE IN SEPARATE CONDUIT AWAY FROM ALL OTHER WIRING.

NOTE: THE FIRST FOUR TERMINALS MUST BE CONNECTED WHEN USING THE 4-20 mA TIMING LOOP - SEE CHART

TO MAG PICKUPS

TO HALL EFFECT PICKUP

WIRE TO BE 16 GA. ALTRONIC 503 188 OR EQUIVALENT

281 550-2
DC CONVERTER

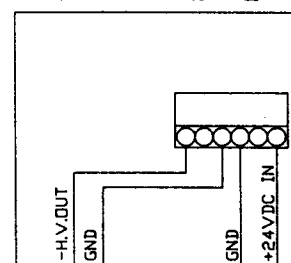

NOTE:

THE NEGATIVE OF THE 24VDC SUPPLY MUST BE COMMON WITH ENGINE GROUND.

NON-INTERRUPTIBLE

+ 24VDC

GND

NOTE:

TERMINALS 2, 4, AND 11 ARE ELECTRICALLY COMMON.

REVISIONS				TOLERANCES (EXCEPT AS NOTED)		ALTRONIC INC.		
NO.	DATE	BY	DESCRIPTION	DECIMAL		TITLE		
1				.XXX	±.005	CPU II AND DC CONVERTER WIRING		
2				.XX	±.010	DRAWN BY WTP SCALE NONE PART NUMBER		
3				FRACTIONAL		CHECKED BY		DATE 6-17-88
4				MATERIAL		APPROVED BY		209 061A
5								

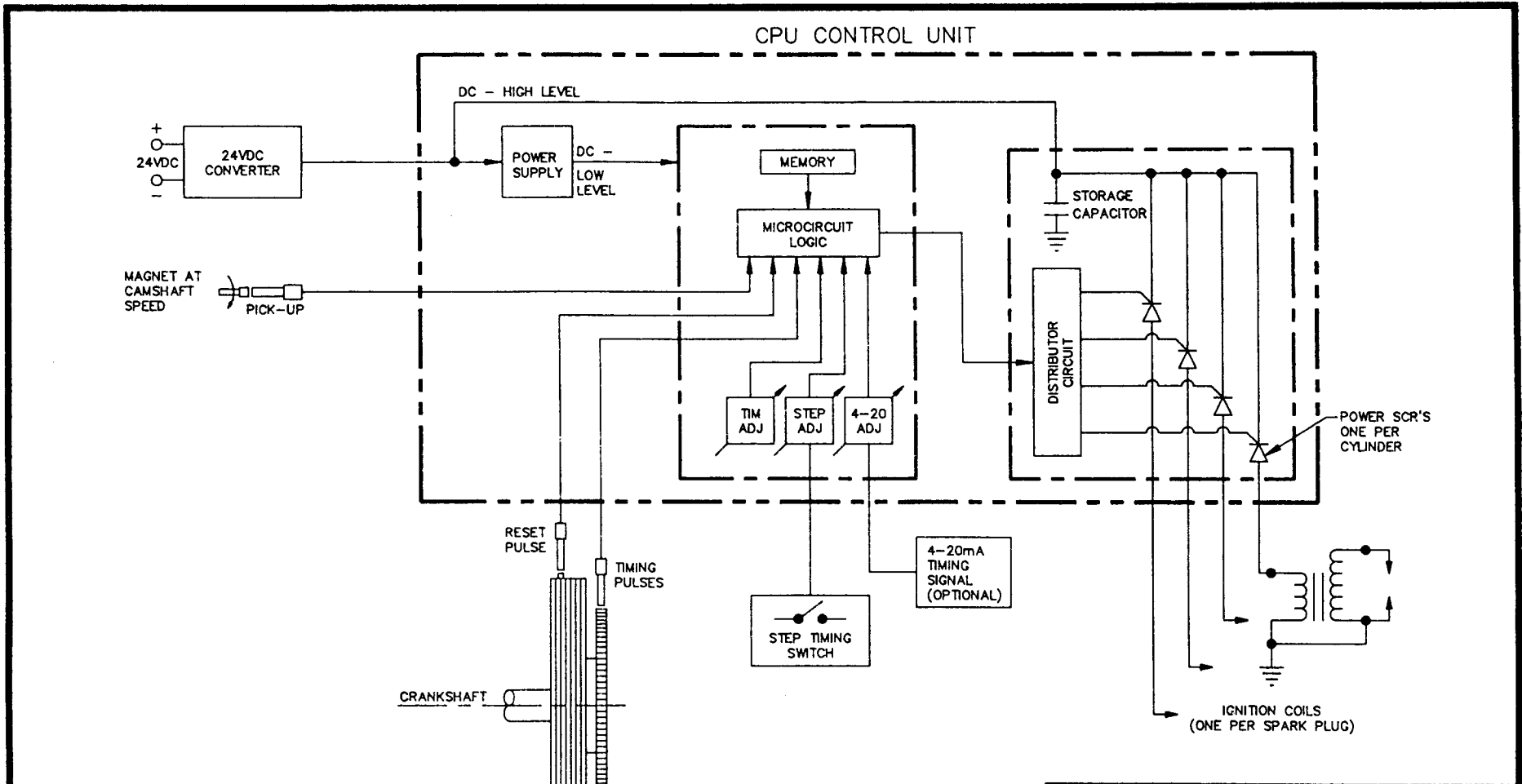

REVISIONS			
NO.	DATE	BY	DESCRIPTION
1			
2			

TOLERANCES (EXCEPT AS NOTED)		ALTRONIC INC.	
DECIMAL .XXX - ±.005 .XX - ±.010		TITLE DC-CPU BLOCK DIAGRAM	
FRACTIONAL	DRAWN BY WTP	SCALE NONE	PART NUMBER
MATERIAL	CHECKED BY	DATE 6-7-88	209 107A
	APPROVED BY		

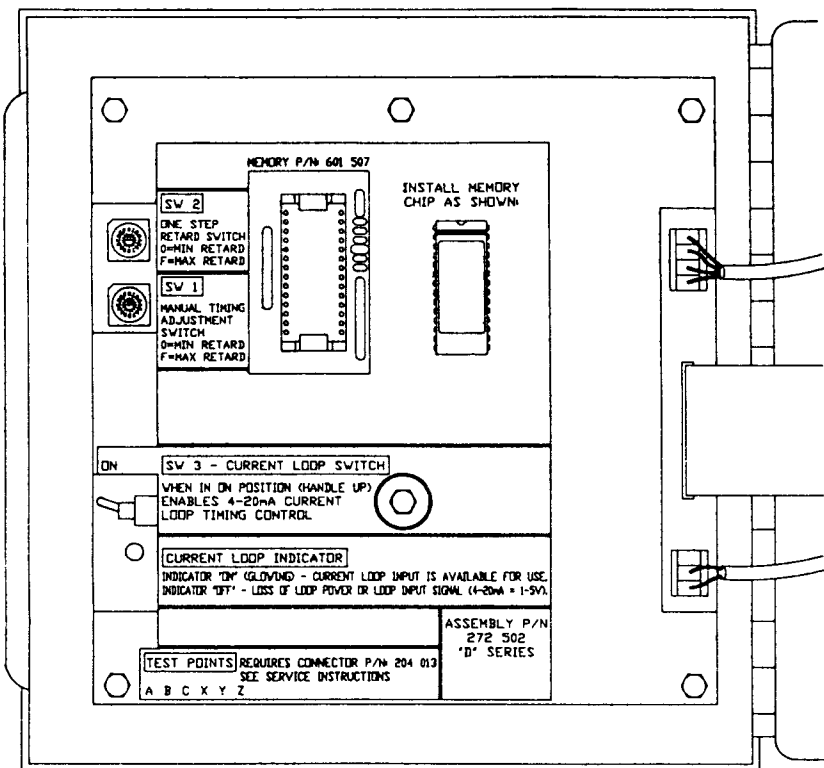

TIMING SWITCH SW1

MANUAL TIMING ADJUSTMENT USED TO SET THE FULL ADVANCE TIMING POSITION OF THE SYSTEM. POSITION 0 IS MIN. RETARD; POSITION F IS MAX. RETARD. EACH ADDITIONAL SWITCH POSITION RETARDS THE TIMING BY ONE TOOTH DEGREE.

TIMING SWITCH SW2

ONE-STEP TIMING CHANGE CONTROLLED BY EXTERNAL CONTACTS CONNECTED BETWEEN TERMINALS 5 AND 6 (SEE DRAWING 209 104A). THE EXTERNAL CONTACTS ARE NORMALLY CLOSED AND ARE OPENED TO ENABLE ADDITIONAL RETARD SET BY SW2. POSITION 0 IS MIN. RETARD; POSITION F IS MAX. RETARD. EACH ADDITIONAL SWITCH POSITION ADDS AN ADDITIONAL TOOTH DEGREE TO THE ONE-STEP TIMING CHANGE.

TIMING SWITCH SW3

CONTROLS WHETHER EXTERNAL 4-20mA CONTROL LOOP SIGNAL IS ACTIVE OR NOT. LOOP SIGNAL AND POWER ARE CONNECTED TO TERMINALS 1-4 (SEE DRAWING 209 104A). OPEN POSITION OF SW3 ALLOWS THE INFLUENCE OF THE 4-20mA LOOP; CLOSED POSITION DELETES ANY INFLUENCE FROM THE LOOP. 4mA IS MIN. RETARD, 20mA IS MAX. RETARD.

NOTES:

- 1) SWITCH SW1 IS ALWAYS OPERATIONAL. SWITCHES SW2 AND SW3, WHEN ACTIVATED, PROVIDE FOR ADDITIONAL RETARD CAPABILITY. TOTAL RETARD = RETARD SW1 + RETARD SW2 + RETARD SW3.
- 2) ON SW1 AND SW2, POSITIONS A-F REPRESENT 10-15 (TOOTH DEGREES OF RETARD).

REVISIONS				TOLERANCES (EXCEPT AS NOTED)	ALTRONIC INC.		
NO.	DATE	BY	DESCRIPTION	DECIMAL .XXX - ±.005 .XX - ±.010	TITLE	SCALE	PART NUMBER
1				FRACTIONAL	CPU II CONTROL UNIT TIMING SWITCHES	DRAWN BY	209 108A
2				MATERIAL		WTP	
3					CHECKED BY	DATE	
4					APPROVED BY	5-31-88	
5							

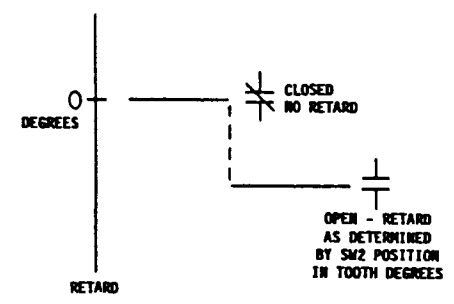
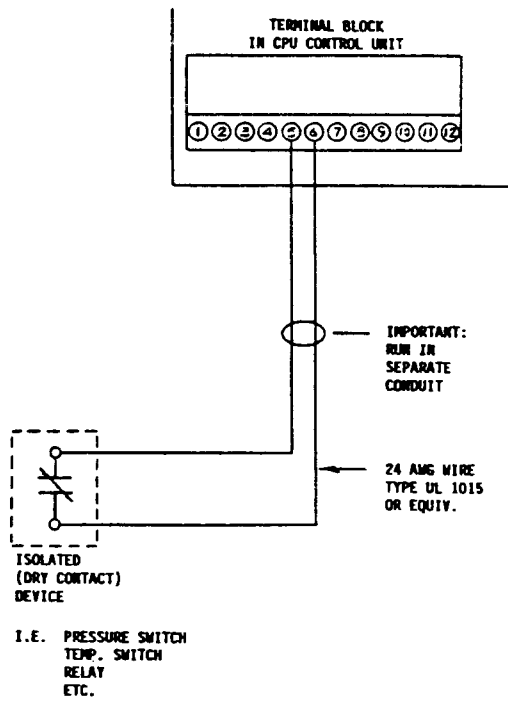

TOLERANCES UNLESS OTHERWISE SPECIFIED .XXX - ±.005 .XX - ±.010	MATERIAL	DRAWN	TRACED	CHECKED	DESIGNER	APPROVED	DATE
	ANALYSIS	DA					5 - 30 - 85
		ALTRONIC, INC.					SCALE
		GIRARD (YOUNGSTOWN), OHIO					
		NAME TIMING CURVE ONE - STEP					PART NO. 209109

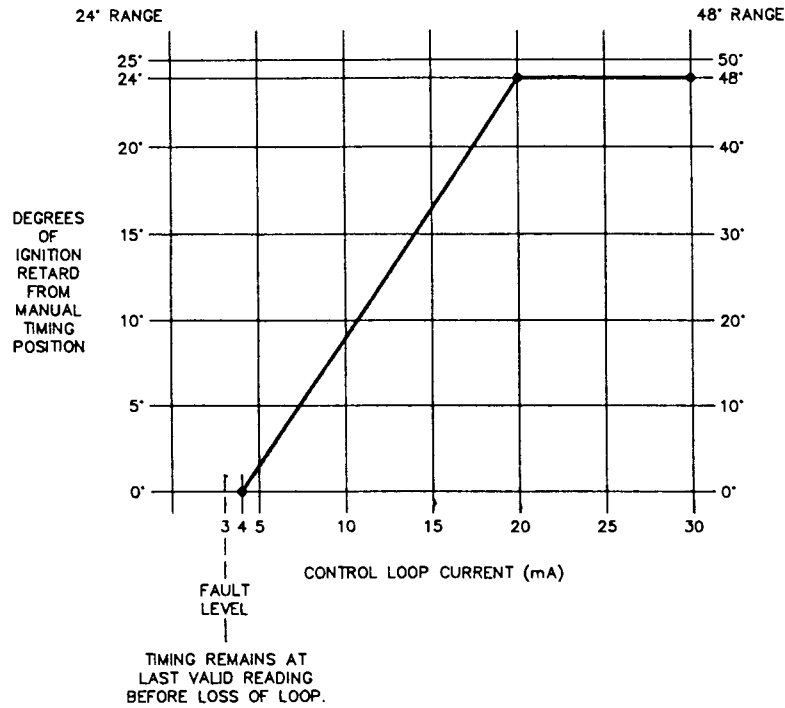

2-WIRE TRANSMITTER

EXAMPLE: ROSEMONT, FOXBORO

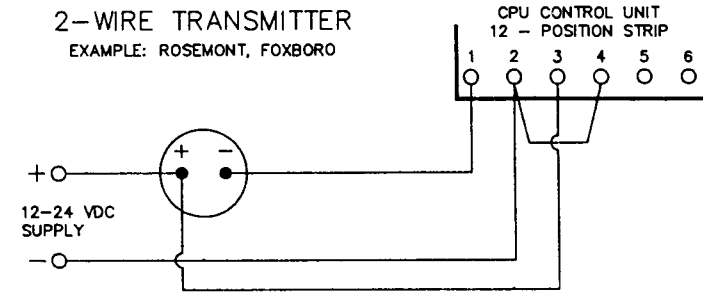

3-WIRE TRANSMITTER

EXAMPLE: ALTRONIC 1201P, 1301P, 1501P, EPC

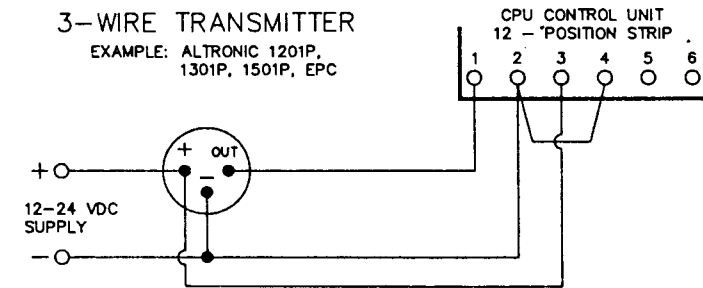

NOTE:

1. LOOP INPUT IMPEDANCE: 250 OHMS $\pm 1\%$
POWER REQUIREMENT: 12-24 VDC, 50mA
2. TERMINALS 2 AND 4 ARE ELECTRICALLY COMMON NEGATIVE.
3. FIELD WIRING MUST BE 24 AWG UL STYLE 1015 TYPE WIRE IN SEPARATE CONDUIT AWAY FROM ALL OTHER WIRING.

REVISIONS				TOLERANCES (EXCEPT AS NOTED)	ALTRONIC INC.		
NO.	DATE	BY	DESCRIPTION	DECIMAL XXX - ± 0.05 XX - ± 0.10	TITLE		PART NUMBER
1	2-7-86		UPDATE	FRACTIONAL	TIMING CURVE 4-20mA		209 110
2	5-31-88	WTP	REVISED INPUT CIRCUIT; REDRAWN ON CAD	MATERIAL	DRAWN BY	DA	
3					CHECKED BY	DATE	
4					APPROVED BY	SCALE	
5						NONE	
						DATE	11-7-85

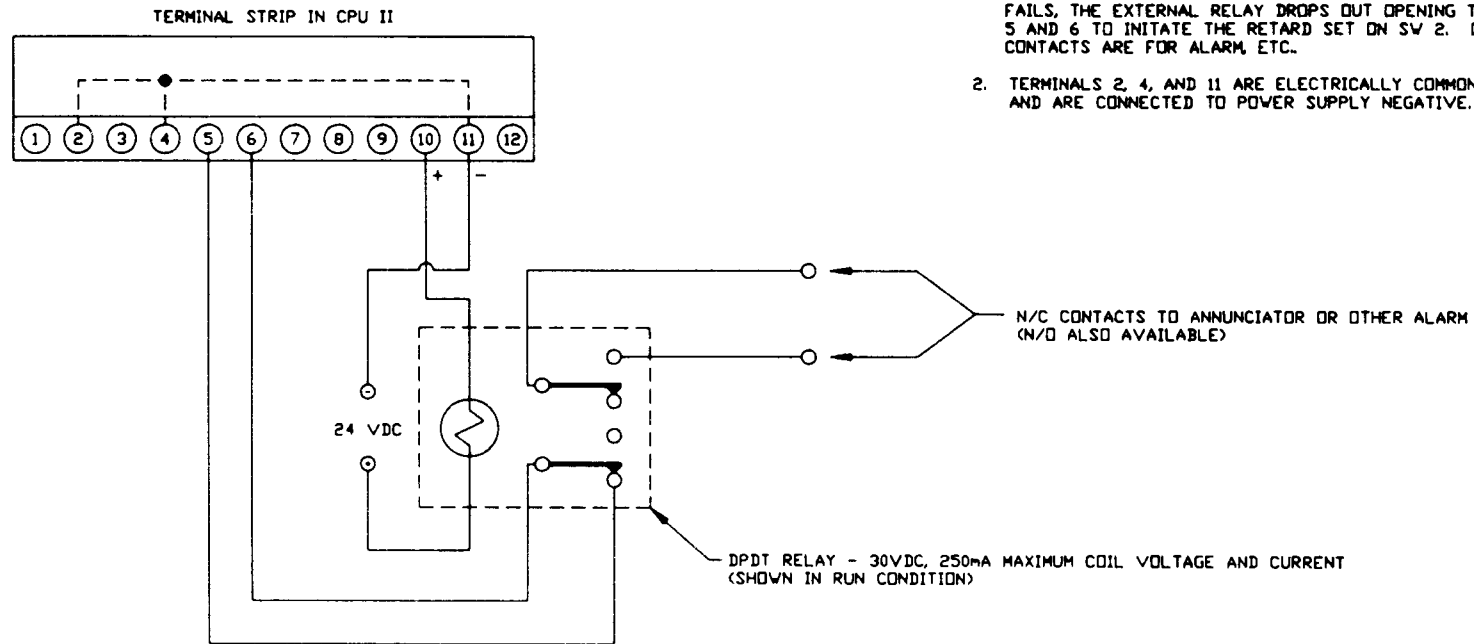

NOTES:

1. TERMINALS 10 AND 11 ARE CLOSED IN A RUN CONDITION WHICH ENERGIZES EXTERNAL RELAY. IF 4 TO 20mA SIGNAL FAILS, THE EXTERNAL RELAY DROPS OUT OPENING TERMINALS 5 AND 6 TO INITATE THE RETARD SET ON SV 2. OTHER CONTACTS ARE FOR ALARM, ETC.
2. TERMINALS 2, 4, AND 11 ARE ELECTRICALLY COMMON AND ARE CONNECTED TO POWER SUPPLY NEGATIVE.

REVISIONS				TOLERANCES EXCEPT AS NOTED	ALTRONIC INC.		
NO.	DATE	BY	DESCRIPTION	DECIMAL XXX - 0.005 XX - 0.010	TITLE		PART NUMBER
1				FRACTIONAL	DRAWN BY	WTP	SCALE NONE
2				MATERIAL	CHECKED BY	DATE	5-24-88
3					APPROVED BY		
4							
5							

TITLE: AUTO RETARD ON LOSS OF LOOP - CPU II

SCALE: NONE

DATE: 5-24-88

PART NUMBER: 209 111

TO SHORTEN HARNESS

1. LOOSEN AND DISENGAGE NUT (2) AND REMOVE CONDUIT (1) COMPLETELY FROM CONNECTOR AND HARNESS ASSEMBLY (3).
2. REMOVE ITEMS (5), (4), AND (2) IN THAT ORDER FROM CONDUIT (1). NOTE THREADS ON (5).
3. CUT CONDUIT TO LENGTH WITH HACKSAW AND DRESS WITH FILE TO INSURE A CLEAN, SQUARE END. REMOVE FILINGS FROM INSIDE CONDUIT.
4. REINSTALL ITEMS (2), (4), AND (5) IN THAT ORDER.
5. INSTALL REASSEMBLED CONDUIT INTO (3) AND TIGHTEN (2).

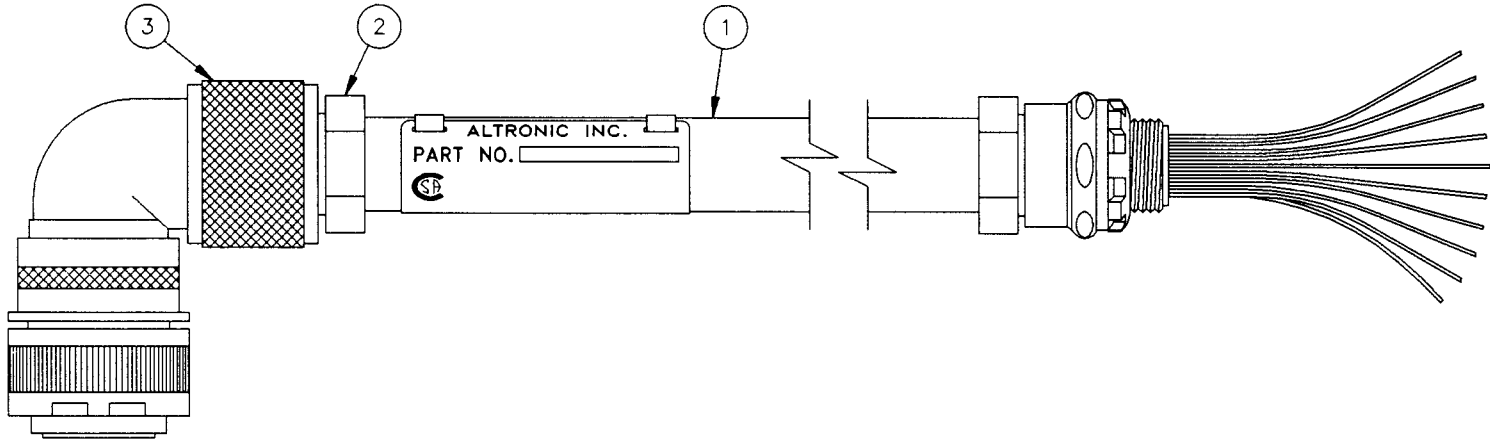
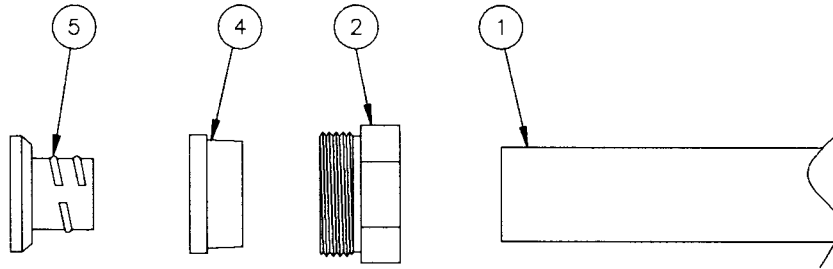

REVISIONS				TOLERANCES (EXCEPT AS NOTED)		ALTRONIC INC.		
NO.	DATE	BY	DESCRIPTION	DECIMAL	FRACTIONAL	TITLE		PART NUMBER
1	3-14-92	WTP	REDRAWN ON CAD	.XXX - ±.005		SHIELDED HARNESS CONDUIT LENGTH ADJUSTMENT		
2				.XX - ±.010		DRAWN BY	DWA	
3						SCALE	NONE	
4						CHECKED BY	DATE	
5						APPROVED BY	5-28-85	

591014

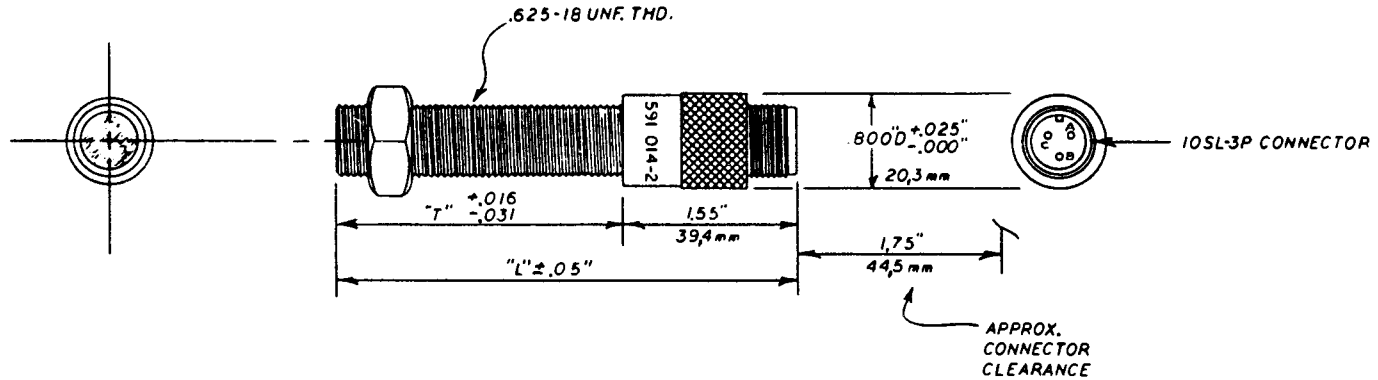

NOTE:

- 1. N-POLE OF MAGNET MUST FACE SENSING END WITH AIR GAP OF .030"-.040" (.76/1.0)
- 2. CENTERLINE OF MAGNET'S ROTATION MUST RUN THROUGH CENTERLINE OF PICKUP.

ALT. P/N	"T"	"L"
591 014-2	2.500" / 63.5 mm	4.055" / 103 mm

TOLERANCES UNLESS OTHERWISE SPECIFIED .XXX - ±.005 .XX - ±.010	MATERIAL	DRAWN	TRACED	CHECKED	DESIGNER	APPROVED	DATE
	ANALYSIS	DWA					1-26-88
ALT II CPU		ALTRONIC DIV. OF ECONOMY ENGINE CO. GIRARD (YOUNGSTOWN), OHIO					SCALE
		NAME HALL EFFECT PICKUP SALES DWG.					PART NO. 591 014

