

# ECV 5 Emissions Control Valve

## Air/Fuel Ratio Control For Gas Engines

- Maintains emissions compliance even with changes in speed and load
- Wide range load control
- Meets tomorrow's emission standards today
- Full authority
- Fully automatic
- Installation kit
- Modbus communication
- Optional display
- Catalyst temperature monitoring
- Handles changes in gas BTU
- Controls rich or lean burn engines
- Can Bus J-1939

### EMISSIONS REQUIREMENTS

The ECV 5 valve offers full authority fuel control for almost any size of gas engine. The variable pressure control technique allows for fast acting control that can include single setpoint steady state control, or, where emissions requirements are extremely low, it can provide mapped load versus fuel input, or even dithering around a dynamic setpoint to optimize the performance of the three-way catalyst.

### THE SOLUTION

Altronic offers a complete system that will maintain the emissions levels of all gas engines in compliance with the most severe local, state, and federal emissions regulations, while maintaining peak operating efficiency.

Ideally the ECV 5 will be used to control fuel pressure to an Altronic mixing venturi to achieve the lowest possible emissions under all load conditions. The ECV 5 can also be used as the primary fuel valve controlling fuel to the carburetor on an after-market AFR installation. The ECV 5 is basically an electronic variable pressure regulator that will vary the fuel pressure to the engine based on a load input and/or an input from a Wide Band Oxygen Sensor. The ECV 5 also can accept an input from the Catalyst Monitor via Can Bus to dynamically adjust the O2 Sensor setpoint based on changing sensor or catalyst conditions. Venturi will automatically accommodate the change by allowing the precise amount of fuel for the amount of air to the engine. No mechanical action is required to make this fuel adjustment.



*ECV 5 with  
TCA 75 Display  
wide band  
oxygen sensor  
and typical  
install kit.*



Class I, Div 2,  
Group D: T4  
ISO 9001:2008  
CERTIFIED

# MAXIMIZE CONTROL

## HOW THE SYSTEM WORKS

The functional diagram below is used to explain the operation of the ECV 5 and the system. The ECV 5 is an electronically controlled valve that functions as a zero pressure regulator with no droop. A precise low pressure transducer is embedded in the valve and is used to sense the discharge pressure, which is the gas injection pressure to the carburetor or mixing venturi device.

## CLOSED LOOP PRESSURE CONTROL

The discharge pressure is compared to the pressure set point as shown in the diagram below. The proportional and integral control provide a fast responding, no-droop pressure regulator. The pressure set point is the default pressure and is selected to run the engine when the O<sub>2</sub> sensor is not operating. This set point is occasionally adjusted by the dynamic input from the optional catalyst monitor or other outside controller or load input.

## SUPPORT FOR WIDE BAND OXYGEN SENSOR (UEGO)

Traditionally, most Air/Fuel Controllers for gas engines have supported only a narrow band Zirconia Sensor. These are a switching type of sensor quickly switching back and forth from a rich to a lean indication. They were designed to operate very near the stoichiometric point on a gasoline engine. This switching signal is not ideal for controlling natural gas engines and the Wide Band (Universal Exhaust Gas Oxygen Sensor UEGO) is a faster, more stable, sensor that drifts less, and is all-around a more suitable sensor for controlling the AFR of Natural Gas Engines. For this reason, our products are designed to accept an input from the Wide Band (UEGO) sensor not the older narrow band sensor. The use of the Wide Band Sensor also allows Altronic AFR products to be used in rich burn applications with less than .5% O<sub>2</sub> in the exhaust to lean burn applications with as much as 12% O<sub>2</sub> in the exhaust.

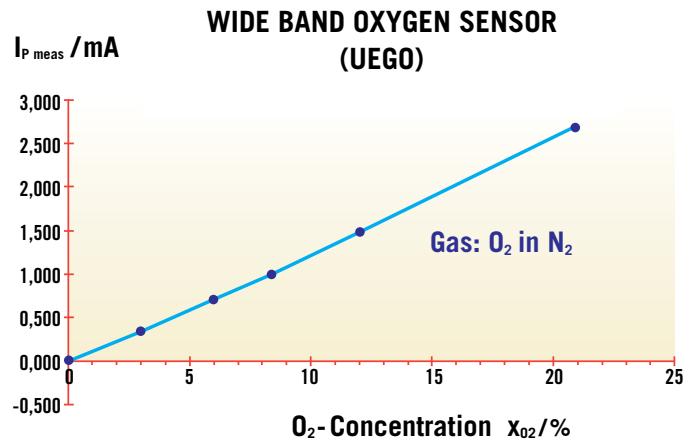

## GAS SUPPLY PRESSURE

The required minimum gas supply pressure is the sum of the gas injection pressure and the pressure drop across the valve. The valve pressure drop is a function of the flow through the valve and is shown in the diagram in the next column. The supply pressure should be regulated to ideally allow the ECV 5 to operate in the 50% to 75% range when the engine is at full load.

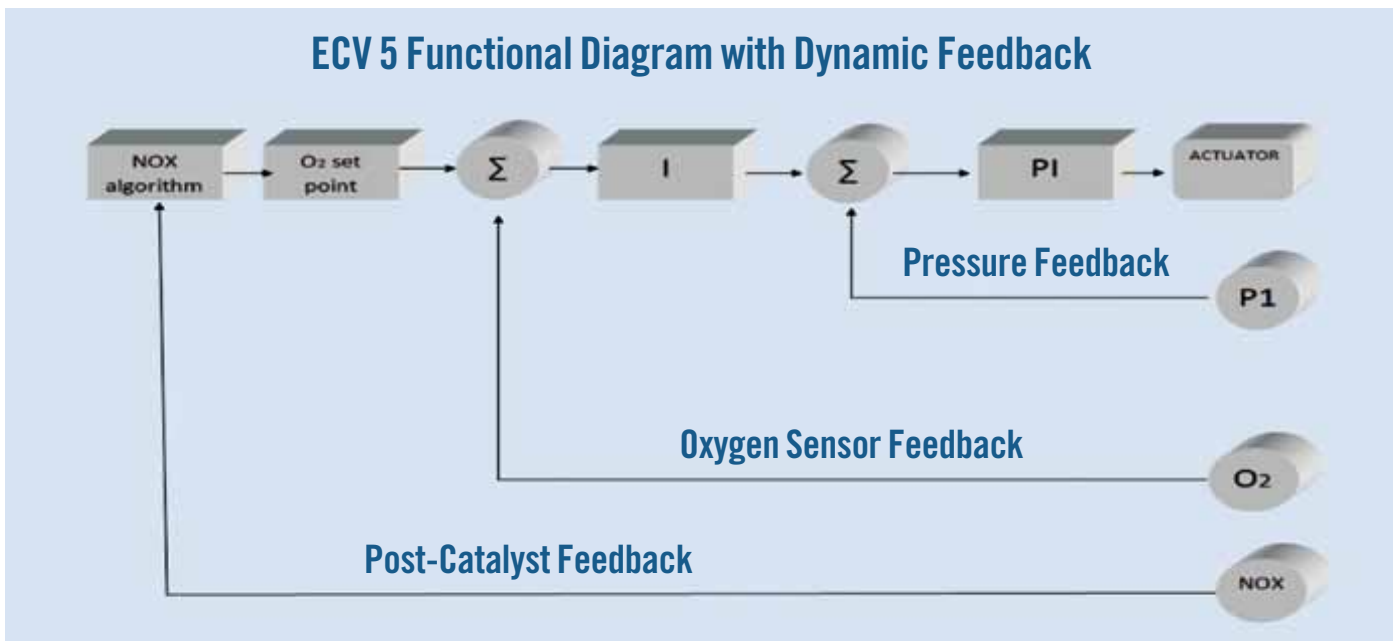

## MINIMIZE EMISSIONS

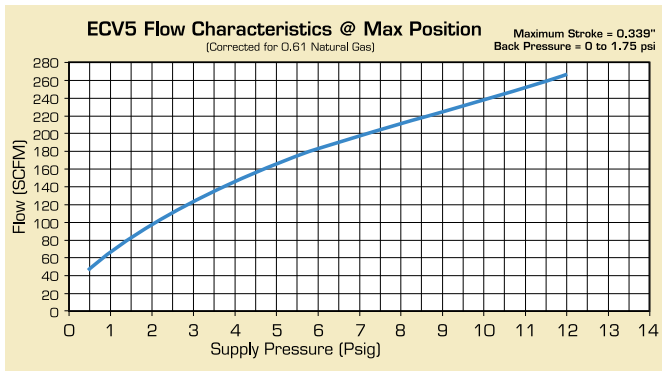

As can be seen from the chart, if the injection pressure is zero and the gas flow is 60 scfm, 1 psi of gas pressure is required.

## TURBOCHARGED ENGINES

The fuel system of engines turbocharged after the carburetor will be connected like the naturally aspirated engines. When the turbocharger is before the carburetor, a reference line must be connected from the air inlet of the carburetor to the reference port on the ECV 5.

## DUAL BANK ENGINES

Dual bank engines with a single point of fuel injection and a single turbocharger are connected like a single bank engine. A dual bank engine with a turbocharger for each bank and an O<sub>2</sub> sensor on each bank will require an ECV 5 primary on one side and an ECV 5 secondary on the other side of the engine. Each will be connected with its own O<sub>2</sub> sensor.

## LOAD TRANSIENTS RESPONSE

The valve is very fast and will transition from open to closed in less than 50ms. This will result in a very fast responding pressure regulator. If a load transient occurs, the fuel flow will change and the valve will adjust its position almost instantly and change to minimize the effect of the transient. The engine will run through the transient without falling out of compliance.

## REDUCED EMISSIONS

Since the ECV 5 eliminates much of the lag in the response of the fuel system, the control loop gain can be higher, which will control the O<sub>2</sub> sensor voltage very close to its set point. The ECV 5 can maintain the oxygen content in the exhaust within the NSCR compliance window for 3-way catalysts or at the desired control point for all other applications. This can provide the lowest possible emissions control or the maximum achievable efficiency depending on the control point of the ECV 5.

## DESCRIPTION OF THE ECV 5

The ECV 5 is an electronically controlled servo valve. The electronic assembly is located inside the cover and includes an embedded microcomputer. The main components of the valve include: the poppet valve, the voice coil actuator, the LVDT for position feedback, and the pressure transducer. The valve has two control loops that are closed with feedback. The inner loop is the position control with the LVDT providing the position feedback signal. This inner loop gives the valve unusually fast response.

The outer loop is the pressure control with the pressure transducer providing the feedback signal. The pressure control amplifier is proportional and integral, which is required to operate the valve without droop, meaning the pressure does not change when the gas flow changes.

The valve is nearly all aluminum, except for the magnetic steel parts and the stainless steel shaft.

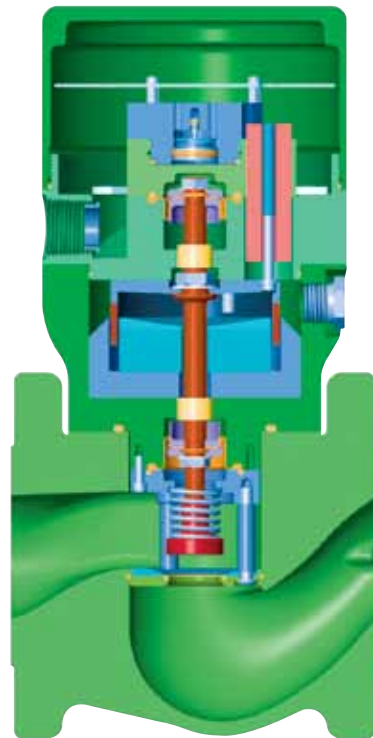

## DESIGN FEATURES

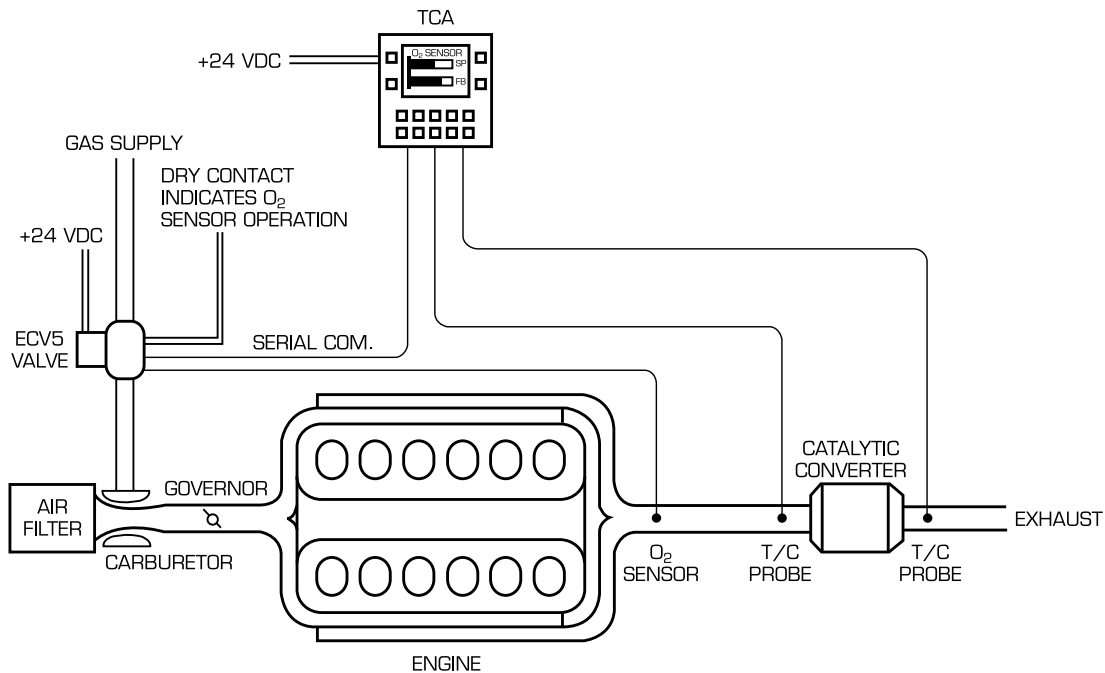

### USER INTERFACE (DISPLAY & CONTROL)

The TCA Control Unit provides the user interface with the system. It also monitors the operation of the system and displays all data available. The TCA also provides the means for changing the set points for the starting pressure and certain control set points and selected parameters. Some of the adjustments are not available by the TCA without password authorization. The TCA includes graphic display in the form of bar graphs with numeric values. The operation of the system is monitored by selecting one of the following parameters to be displayed:

- Gas injection pressure and its set point
- Oxygen sensor voltage and its set point
- Valve position
- Default pressure
- Pre- and post-catalyst temperature

The TCA is a miniature PLC and is programmed to provide an over-temperature alarm or shutdown to prevent damage to the catalytic converter. The TCA can be used to monitor the temperature rise in the catalyst due to the exothermic reaction. The differential temperature can be displayed, logged and exported via the serial port. The TCA also is provided with a serial port for ModBus communications with other control and data logging systems.

### INSTALLATION

The ECV 5 system is very easy to install and simple to set up for any engine. The complete kit, including: wiring, cables, sensors and display unit, is available as an option. The figure above illustrates the wiring necessary to fully implement the system.

### CATALYTIC CONVERTER

To maximize reduction of NO<sub>x</sub>, CO and HC's, the ECV 5 is used on a rich burn engine with a 3-way catalytic converter in the exhaust. An oxygen sensor is placed in the exhaust stream before the converter. The ECV 5 valve controls the air fuel mixture to maintain very precise control of oxygen content in the exhaust at the oxygen sensor. This precise control will not only maximize the effectiveness of the catalyst which will allow the system to meet the most stringent emissions requirements, but it will also extend the life expectancy of the catalyst.

When the emission requirements are not stringent enough to currently require the use of a 3-way catalyst, the ECV 5 can be used to control in a lean burn mode with or without an Oxidation Catalyst. In this mode the operator will tune the ECV 5 for the mixture that provides maximum efficiency for the engine or by adding the Oxidation Catalyst improved efficiency with low CO and VOC's.

**altronic**

712 Trumbull Avenue, Girard, Ohio 44420  
(330) 545-9768 / Fax: (330) 545-3231  
Email: sales.altronic.girard@hoerbiger.com  
Form ECV 5 6-18