

## 691118 SERIES MAGNETIC PICKUPS

### FEATURES:

- Stainless steel case
- MS 2-pin output connector (10SL-4P)
- Encapsulated in glass-filled epoxy
- Suitable for use in engine oil
- Voltage limiting Zener diodes (see below)
- Nominal resistance: 1,500 ohms
- Nominal inductance: 500 mH
- Operating Temperature:  
-65°F to 225°F / -54°C to 107°C

### APPLICATIONS:

- Engines and turbines
- Pumps and compressors
- Any industrial rotating equipment

### CIRCUIT DIAGRAM:

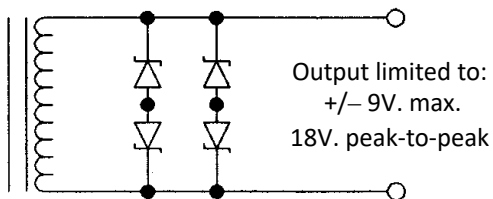

Altronic P/N	Thread Lg. "T"	Overall Lg. "L"
691118-1	1.75"/44.5mm	3.30"/83.3mm
691118-2	2.5"/63.5mm	4.05"/102.8mm
691118-3	3.0"/76.2mm	4.55"/115.6mm
691118-4	4.5"/114.3mm	6.05"/153.7mm
691118-6	6.0"/152.4mm	7.55"/191.8mm

See Dimensions on next page.



CERTIFIED CLASS I,  
DIVISION 1 and 2,  
GROUPS A,B,C,D

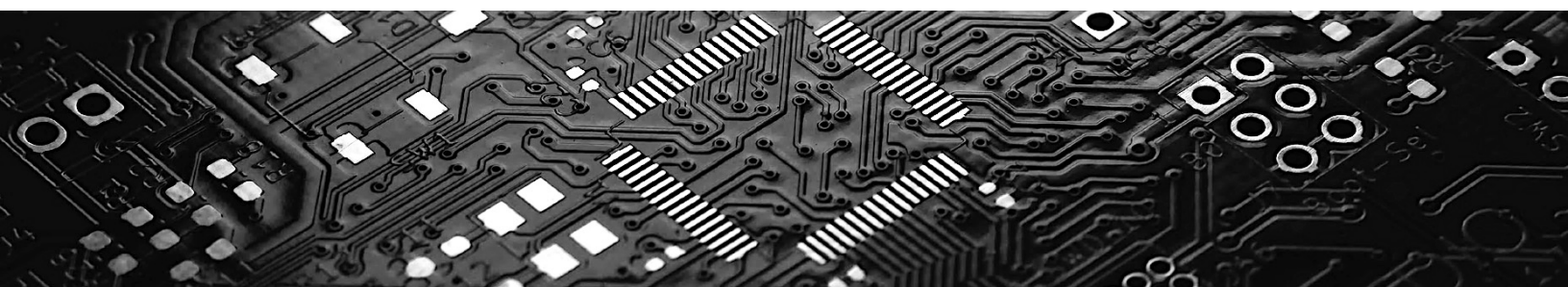

## Altronic Magnetic Pickup Cable Options

Type	Part No.	Connector	Cable Length	Conduit Length "X" (inches)
Unshielded	693104-1	180°	10 ft.	
	693104-2	180°	20 ft.	
	693104-3	180°	30 ft.	
	693104-4	180°	40 ft.	
	693104-5	180°	50 ft.	
Shielded	593048-X	180°	50 ft.	12, 18, 24, 36, 48, 72, 96, 120
	593048A-X	180°	100 ft.	24, 48, 72, 96
	593054-X	90°	50 ft.	12, 18, 24, 36, 48, 72, 96, 120
	593054A-X	90°	100 ft.	24, 48, 72, 96

Note: Above shielded cables are certified for Class I, Div. 2, Group D hazardous locations when used with other applicable CSA-certified Altronic components.

## Dimensions

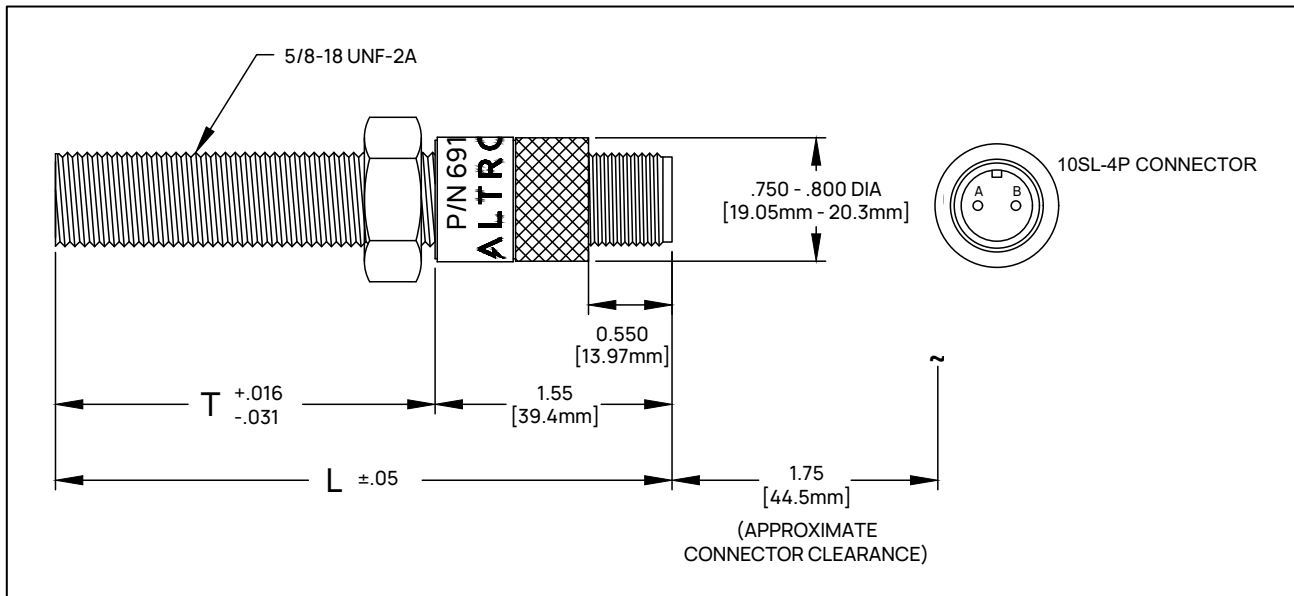

## Operation Description

Magnetic pickups convert mechanical motion into electrical energy without mechanical linkage or external power. These transducers sense any ferromagnetic material having discontinuities such as gear teeth, holes or slots and generate an AC voltage. The frequency of this voltage is equal to the number of discontinuities passing the pickup and is proportional to RPM.

Fig. 1 shows the typical construction of a MPU. The pole piece forms a magnetic path from the magnet, creating an external field in front of the sensor. When this magnetic field is disrupted by a ferromagnetic material, an AC voltage is induced in the coil.

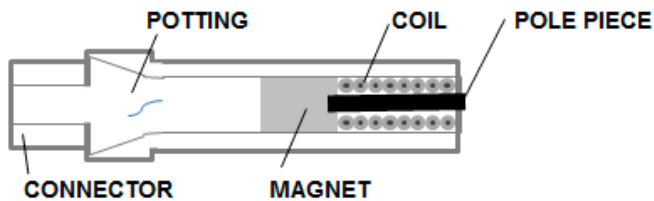

Figure 1

The amplitude of the output voltage depends on the surface speed of the gear, the gap between the pole piece and the gear, the gear tooth size and spacing, and the load impedance. The pickup output voltage is directly proportional to surface speed of the gear. Surface speed is most often expressed in terms of inches per second.

$$\text{Surface Speed (IPS)} = \text{RPM} \times \text{Gear Dia. (inches)} \times 3.1416 / 60$$

Fig. 2 shows the output as a function of surface speed. Note: The Altronic 691118 intrinsically-safe MPU has internal voltage-limiting Zener diodes which limit the output to 18V. peak-to-peak regardless of speed.



Figure 2

Figure 3 gives the optimum dimensions for a gear to be used with a magnetic pickup. If maximum power is required, the gear should be as close as possible to these dimensions. In many applications, small tooth gears are adequate. At high speeds even a 90-pitch may be satisfactory. Pitch is the number of teeth per inch of diameter.

$$\text{Pitch} = \text{Number of teeth} + 2 / \text{Diameter of gear (inches)}$$

$$\text{Diameter} = \text{Number of teeth} + 2 / \text{Pitch}$$

- A. Equal to or greater than D
- B. Equal to or greater than C
- C. Equal to or greater than (3X) three times D
- D. Pickup pole diameter (= 0.157" for MPU 691118)
- E. As close as possible, typically .005"
- F. Equal to or greater than D

Note: If possible use a gear of 16 pitch or coarser.

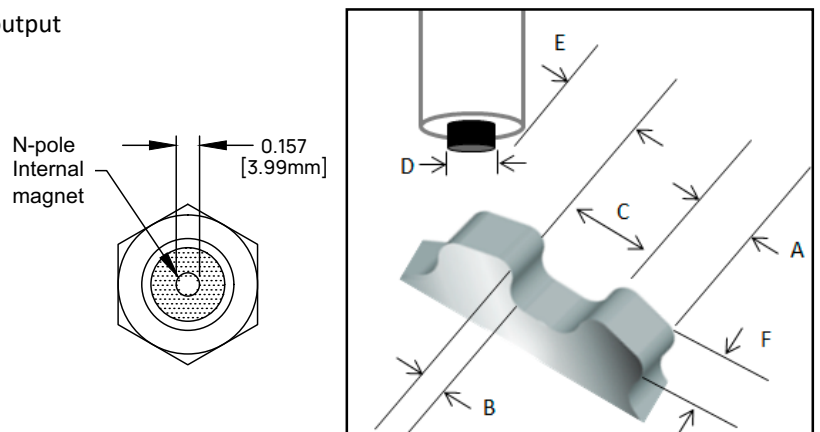

Figure 3

# ALTRONIC

A Member of the HOERBIGER Group

712 Trumbull Avenue / Girard, Ohio 44420  
(330) 545-9768 / Fax: (330) 545-3231

www.altronic-llc.com / Email: [sales@altronic-llc.com](mailto:sales@altronic-llc.com)

Form 691118 6-25 ©2025 Altronic, LLC

