

ALTRONIC ,INC.  
712 TRUMBULL AVE.  
GIRARD, OHIO 44420

**CPU-2000 IGNITION SYSTEM**

**IMPORTANT SAFETY NOTICE**

**PROPER INSTALLATION, MAINTENANCE, REPAIR AND OPERATION OF THIS EQUIPMENT IS ESSENTIAL. THE RECOMMENDED PRACTICES CONTAINED HEREIN SHOULD BE FOLLOWED WITHOUT DEVIATION. AN IMPROPERLY INSTALLED OR OPERATING IGNITION SYSTEM COULD CAUSE PERSONAL INJURY TO OPERATORS OR OTHER NEARBY PERSONNEL.**

**TABLE OF CONTENTS**

**ALTRONIC CPU-2000 SERVICE INSTRUCTIONS**

SECTION	ITEM	PAGE
1.0	SYSTEM DESCRIPTION	3
2.0	PARTS IDENTIFICATION AND SPECIFICATION	4
2.1	CPU-2000 LOGIC MODULE	4
2.2	CPU-2000 OUTPUT MODULE: 291116-1	6
2.3	CPU-2000 OUTPUT MODULE: 291132-1, 291132-2	8
2.4	CPU-2000 DIAGNOSTIC MODULE: 291105-1	11
3.0	TEST STAND REQUIREMENTS	13
4.0	TESTING PROCEDURE-OUTPUT MODULE: 291116-1, 291132-1	15
4.1	Voltage Output Test	15
4.2	Operational Test	15
5.0	OHMMETER CHECKS	15
5.1	CPU-2000 Output Module	15
6.0	OSCILLOSCOPE TESTS	16
6.1	Test Set-up	16
6.2	Storage Capacitor Voltage Pattern	16
6.3	Multi-Strike Tests	16
7.0	TESTING PROCEDURE - CPU-2000 LOGIC MODULE	17
7.1	Operational Tests	17
7.2	Timing Tests	17
8.0	TESTING PROCEDURE - CPU-2000 DIAGNOSTIC MODULE	17
8.1	Operational Tests	17
9.0	TROUBLESHOOTING	18
9.1	Power Module	18
9.2	Logic Module	18
9.3	Logic Module Diagnostic Messages	18
9.4	Diagnostic Module	19
10.0	BOARD REPLACEMENT PROCEDURE - OUTPUT MODULE TOP POWER	19
10.1	Disassembly Procedure	19
10.2	Assembly Procedure	19
11.0	BOARD REPLACEMENT PROCEDURE - OUTPUT MODULE BOTTOM POWER	19
11.1	Disassembly Procedure	19
11.2	Assembly Procedure	19
12.0	BOARD REPLACEMENT PROCEDURE - LOGIC MODULE DISPLAY BOARD	20
12.1	Disassembly Procedure	20
12.2	Assembly Procedure	20
13.0	BOARD REPLACEMENT PROCEDURE - LOGIC MODULE LOGIC BOARD	20
13.1	Disassembly Procedure	20
13.2	Assembly Procedure	20
14.0	BOARD REPLACEMENT PROCEDURE - DIAGNOSTIC MODULE	20
14.1	Disassembly Procedure	20
14.2	Assembly Procedure	20

## 1.0 SYSTEM DESCRIPTION

- 1.1 The Altronic CPU-2000, DC-powered ignition system is a microprocessor-based capacitor discharge system applicable to slow and medium speed, stationary engines. The system requires two signals from external magnetic pickups and one from a Hall-effect pickup. The first magnetic pickup is needed to count holes or gear teeth on the engine flywheel. The second is used to give a reset pulse once every revolution of the crankshaft. The hall-effect pickup is referenced to the camshaft and is used to reference the compression stroke on four-cycle applications.
- 1.2 The CPU-2000 ignition system consists of two main parts; a user interface Logic Module and an engine mounted Output Module. The Logic Module has an alphanumeric LCD display showing the operating status, engine RPM, energy level, single or multi-striking mode, current loop input value and ignition timing. Additional display screens show set-up and diagnostic information. Precise timing pulses are generated on the Logic module and are routed to the Output Module in order to fire the ignition coils. Circuitry in the Output Module converts 24 volts DC to -320 volts and directs energy to the coils in proper sequence. The Output Module is available in 16 and 32-output versions.
- 1.3 An optional Diagnostic Module 291105-1 provides enhanced primary and secondary circuit diagnostics on an individual cylinder basis. Included are displays allowing the user to monitor relative voltage demand at the spark plugs and the capability for the system to automatically set its energy level based upon monitored voltage demand.
- 1.4 Timing changes on the CPU-2000 are derived by counting pulses from the reference teeth. The timing change increment is equal to  $90/N$  where  $N$  = the number of reference teeth or holes. With 180 teeth as recommended for test purposes, the timing increment is one-half degree.
- 1.5 A 24 Vdc, 10 amp DC power supply will be needed to operate the CPU-2000 system. Refer to form CPU-2000 II, section 13.0 and drawing 209 120.

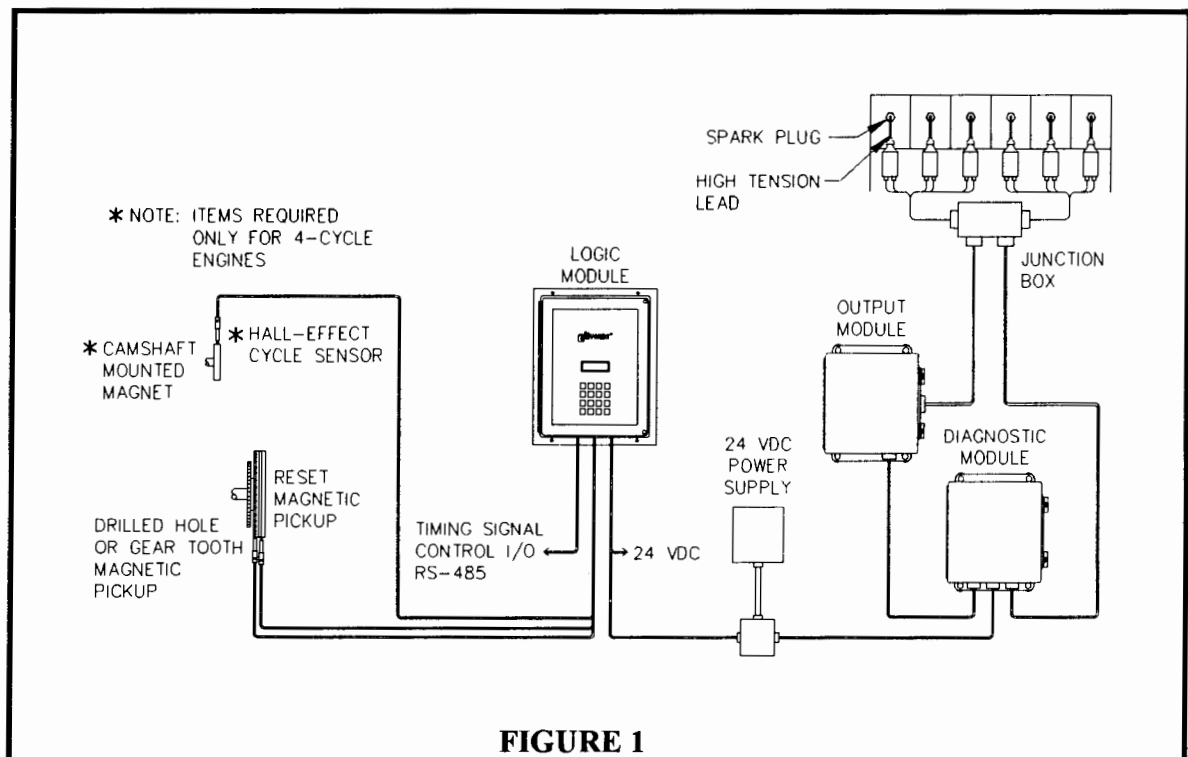

# PARTS IDENTIFICATION

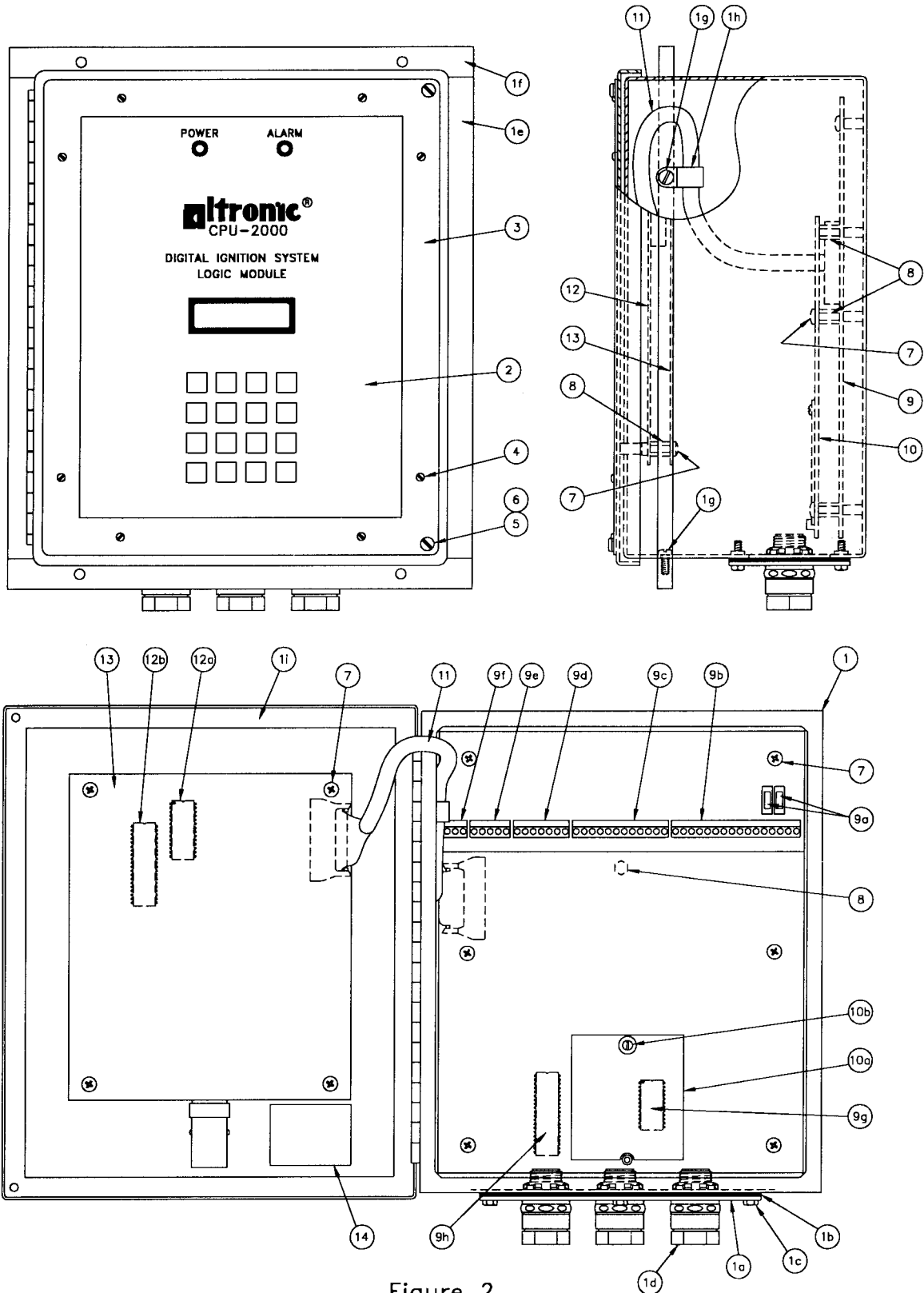

Figure 2

## **2.0 PARTS IDENTIFICATION AND SPECIFICATION**

### 2.1 PARTS LIST - CPU-2000 LOGIC MODULE 291100-1: reference exploded view on page 4.

FIGURE & REFERENCE NO.	QUANTITY	PART NO.	DESCRIPTION
2-1	1	210003	Enclosure
-1a	1	210622	Plate, entry
-1b	1	210625	Gasket, plate
-1c	6	902599	Screw 10-24
-1d	3	510527	Conduit fitting
-1e	2	610220	Mounting bar - vertical
-1f	2	610219	Mounting bar - horizontal
-1g	1	902637	Screw 10-32
-1h	1	610663	Cable strap
-1i	1	610513	Gasket, lid
-2	1	280001-1	Keypad assembly
-3	1	602283-4	Frame
-4	8	902578	Screw 4-40
-5	2	902611	Screw 10-32
-6	2	610443	O-ring
-7	10	902642	Screw 10-32
-8	8	610662	Standoff
-9	1	272007-1	Logic board assembly
-9a	2	601726	Fuse 3A
-9b	1	610242	Receptacle plug 16-position
-9c	1	610307	Receptacle plug 12-position
-9d	1	610604	Receptacle plug 7-position
-9e	1	610320	Receptacle plug 5-position
-9f	1	610241	Receptacle plug 3-position
-9g	1	601668-A	EEProm, blank
-9h	1	601747	Microprocessor, logic board
-10	1	272008-1	Shield board, logic
-10a	1	202009	Shield window
-10b	1	902061	Screw 6-32
-11	1	610583	Cable
-12	1	272006-1	Display board assembly
-12a	1	601707	Eprom, display board
-12b	1	601710	Microprocessor, display board
-13	1	202010	Shield board, display
-14	1	202017A	Label

# PARTS IDENTIFICATION

-9-

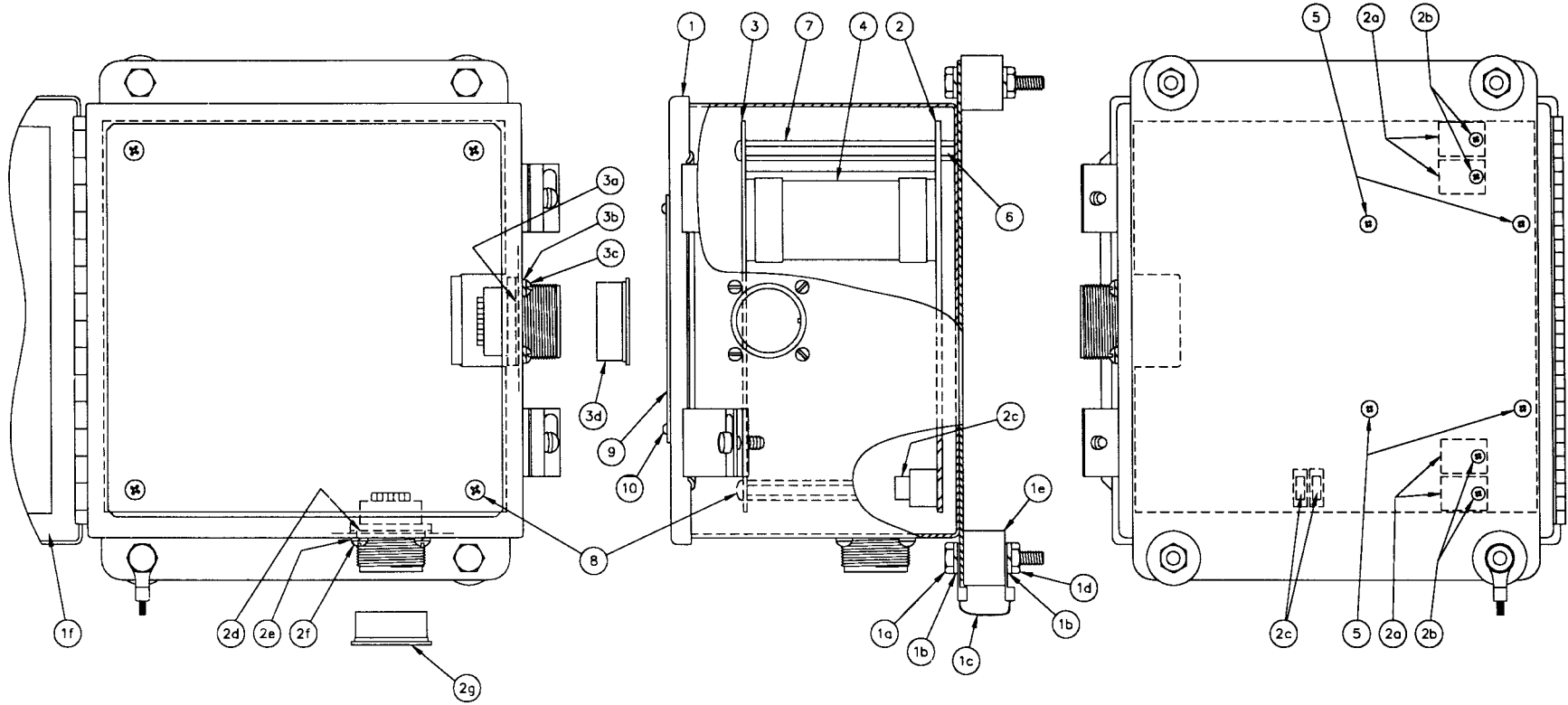

Figure 3

2.2 PARTS LIST - CPU-2000 OUTPUT MODULE 291116-1: reference exploded view on page 6.

FIGURE & REFERENCE NO.	QUANTITY	PART NO.	DESCRIPTION
3-1	1	210001	Enclosure
-1a	4	902593	Bolt 5/16"
-1b	8	901010	Lockwasher 5/16"
-1c	1	610386	Ground strap
-1d	4	902469	Nut 5/16"
-1e	4	610165	Shock mount
-1f	1	610512	Gasket, lid
-2	1	281001-1	Circuit board assembly, bottom
-2a	4	610636	Insulator
-2b	4	902640	Screw 6-32
-2c	2	601725	Fuse 10A
-2d	1	502176	Gasket, connector, 17-pin
-2e	4	901000	Lockwasher #6
-2f	4	902064	Screw 6-32
-2g	1	510561	Cap, connector, 17-pin
-3	1	281002-16	Circuit board assembly, top
-3a	1	501222	Gasket, connector, 19- pin
-3b	4	901000	Lockwasher #6
-3c	4	902064	Screw 6-32
-3d	1	510517	Cap, connector, 19-pin
-4	1	662008	Ribbon cable
-5	4	902615	Screw 8-32
-6	4	710015	Standoff 10-32 (nylon)
-7	4	610664	Standoff 10-32
-8	4	902610	Screw 10-32
-9	1	202011A	Label
-10	4	902578	Screw 4-40

# PARTS IDENTIFICATION

- 8 -

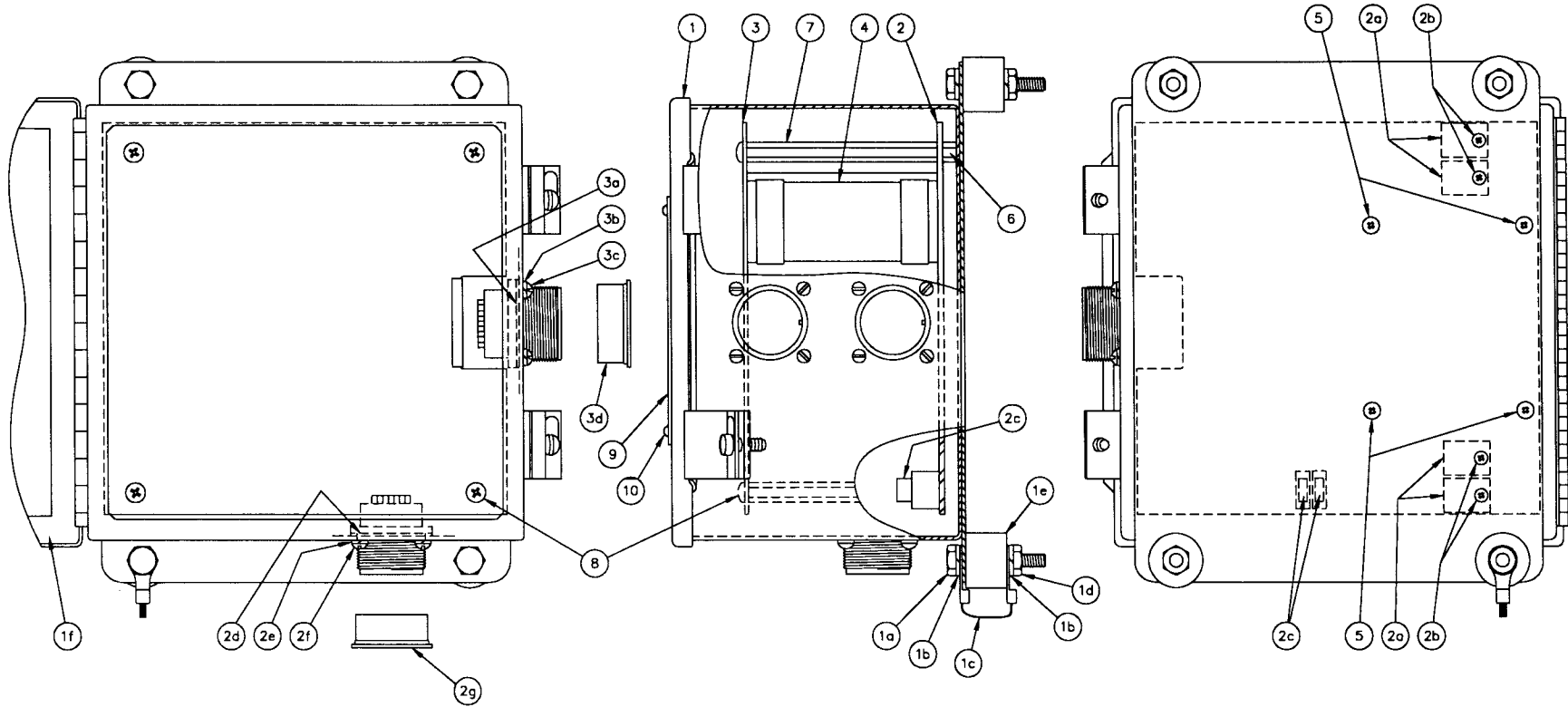

Figure 4



2.3 PARTS LIST - CPU-2000 OUTPUT MODULE 291132-1: reference exploded view on page 8.

FIGURE & REFERENCE NO.	QUANTITY	PART NO.	DESCRIPTION
4-1	1	210002	Enclosure
-1a	4	902593	Bolt 5/16"
-1b	8	901010	Lockwasher 5/16"
-1c	1	610386	Ground strap
-1d	4	902469	Nut 5/16"
-1e	4	610165	Shock mount
-1f	1	610512	Gasket, lid
-2	1	281001-1	Circuit board assembly, bottom
-2a	4	610636	Insulator
-2b	4	902640	Screw 6-32
-2c	2	601725	Fuse 10A
-2d	1	502176	Gasket, connector, 17-pin
-2e	4	901000	Lockwasher #6
-2f	4	902064	Screw 6-32
-2g	1	510561	Cap, connector, 17-pin
-3	1	281002-32	Circuit board assembly, top
-3a	2	501222	Gasket, connector, 19- pin
-3b	8	901000	Lockwasher #6
-3c	8	902064	Screw 6-32
-3d	2	510517	Cap, connector, 19-pin
-4	1	662008	Ribbon cable
-5	4	902615	Screw 8-32
-6	4	710015	Standoff 10-32 (nylon)
-7	4	610664	Standoff 10-32
-8	4	902610	Screw 10-32
-9	1	202011A	Label
-10	4	902578	Screw 4-40

2.3 PARTS LIST - CPU-2000 OUTPUT MODULE 291132-2: reference exploded view on page 8.

FIGURE & REFERENCE NO.	QUANTITY	PART NO.	DESCRIPTION
4-1	1	210002	Enclosure
-1a	4	902593	Bolt 5/16"
-1b	8	901010	Lockwasher 5/16"
-1c	1	610386	Ground strap
-1d	4	902469	Nut 5/16"
-1e	4	610165	Shock mount
-1f	1	610512	Gasket, lid
-2	1	281001-2	Circuit board assembly, bottom
-2a	4	610636	Insulator
-2b	4	902640	Screw 6-32
-2c	2	601725	Fuse 10A
-2d	1	502176	Gasket, connector, 17-pin
-2e	4	901000	Lockwasher #6
-2f	4	902064	Screw 6-32
-2g	1	510561	Cap, connector, 17-pin
-3	1	281002-32A	Circuit board assembly, top
-3a	2	501222	Gasket, connector, 19- pin
-3b	8	901000	Lockwasher #6
-3c	8	902064	Screw 6-32
-3d	2	510517	Cap, connector, 19-pin
-4	1	662008	Ribbon cable
-5	4	902615	Screw 8-32
-6	4	710015	Standoff 10-32 (nylon)
-7	4	610664	Standoff 10-32
-8	4	902610	Screw 10-32
-9	1	202011A	Label
-10	4	902578	Screw 4-40

PARTS IDENTIFICATION

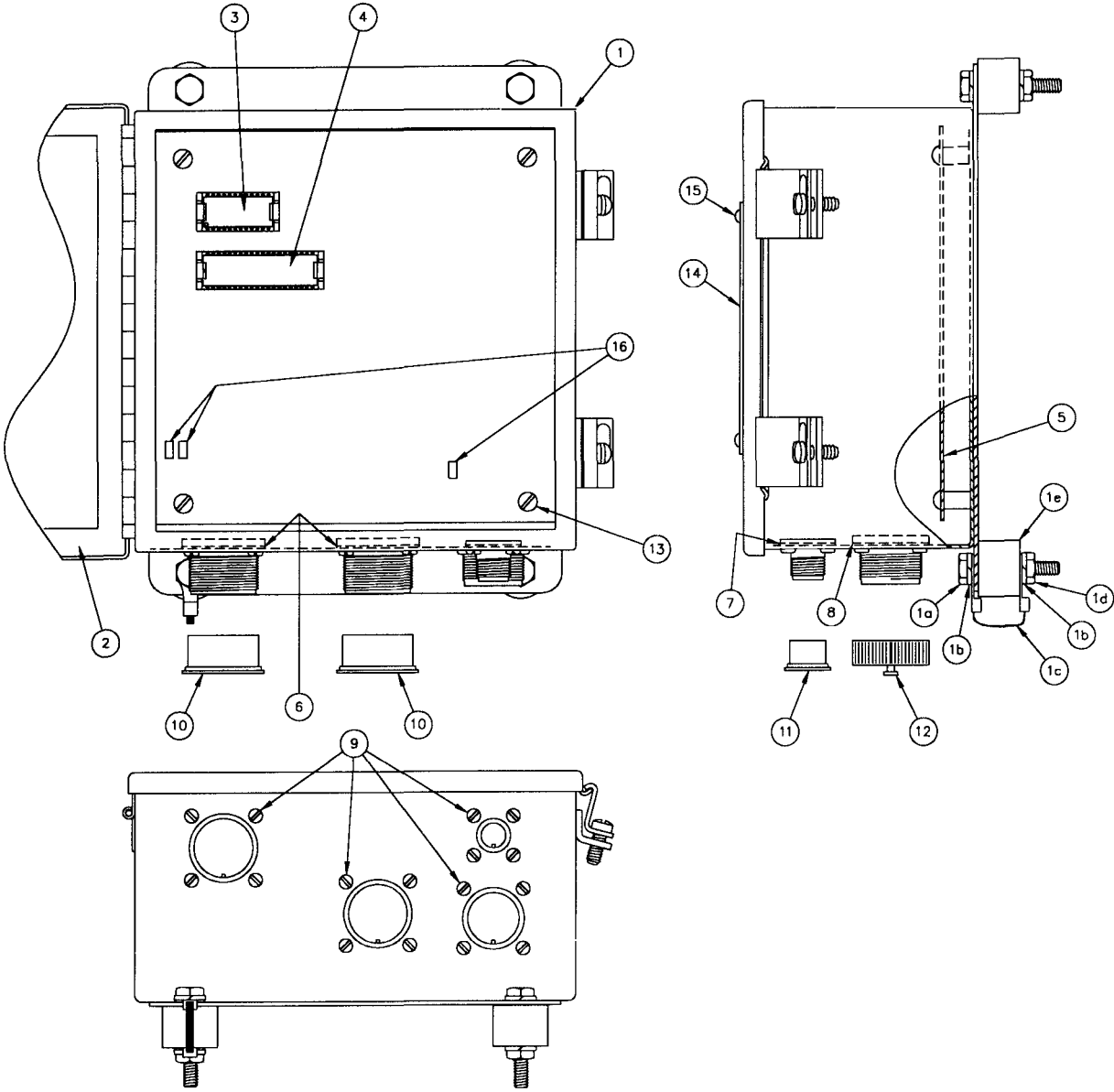

Figure 5

2.4 PARTS LIST - CPU-2000 DIAGNOSTIC MODULE 291105-1: reference exploded view page 11.

FIGURE & REFERENCE NO.	QUANTITY	PART NO.	DESCRIPTION
5-1	1	210004	Enclosure
-1a	4	902593	Bolt 5/16"
-1b	8	901010	Lockwasher 5/16"
-1c	1	610386	Ground strap
-1d	4	902469	Nut 5/16"
-1e	4	610165	Shock mount
-2	1	610512	Gasket, lid
-3	1	601668-A	EEprom, blank
-4	1	601868	Microprocessor
-5	1	272010-1	Circuit board assembly
-6	2	502176	Gasket, connector, 17-pin
-7	1	501369	Gasket, connector, 3-pin
-8	1	501372	Gasket, connector, 10-pin
-9	16	902648	Screw 6-32 seal
-10	2	510561	Cap, connector, 17 pin
-11	1	510516	Cap, connector, 3-pin
-12	1	604122	Cap, connector, 10-pin
-13	4	902439	Screw 10-32
-14	1	202022A	Label
-15	4	902651	Screw 4-40 seal
-16	3	601653	Fuse 6.3A

### **3.0 TEST STAND REQUIREMENTS**

- 3.1 In order to test an Altronic CPU-2000 ignition system, a special test stand is required. The basic test stand is similar to that required for the Altronic II-CPU system.
- 3.2 The following items are required to test the Altronic CPU-2000 system:
- A. A variable speed motor of 0.5 HP or greater, capable of rotating 1500 RPM with a standard ignition drive accepting either flange or base mounting.
  - B. A spark degree wheel graduated in 360 increments with the indicator attached to the shaft driving the Altronic II unit.
  - C. Sixteen (16) 291001 ignition coils connected to suitable, adjustable spark gaps. NOTE: The test stand should incorporate thirty-two (32) ignition coils if 32-output units are tested.
  - D. A source of gear tooth pulses mechanically connected to the Altronic II unit drive; a 180-tooth gear is recommended.
  - E. A single reset pin (6-32 steel machine screw recommended) mounted to the face of the gear.
  - F. Magnetic pickups (691118-x) mounted to sense the gear teeth (A) and the reset pin (B).
  - G. A primary wiring harness connecting the ignition coils to the CPU-2000 Output Module. This requires connector MS3108A-22-14S, Altronic part number 504056. NOTE: Two harnesses are required to test 32-output units.
  - H. A 581602 manual control loop unit to simulate the 4-20mA control signal.
  - I. A DC power source capable of supplying 24Vdc, 10 amps - see Installation Instructions form CPU-2000 II, section 10.4 and drawing 209 120.
  - J. An Altronic II-CPU Alternator; part no. 290213H is recommended. A distributor shaft assembly with 2:1 gear installed is required to test a 4-cycle application. The rotating magnet on the distributor shaft assembly must be over the Hall-effect switch when the reset pin on the test stand is opposite its magnetic pickup.
  - K. An Altronic II-CPU back cover assembly 281500-1 or -2 and mating harness 293024-1. Connect the wiring harness as shown on the following page.
  - L. A blank CPU-2000 EEPROM, Altronic part number 601668-A. Test memories can be used if the Terminal Program is not used. Test memories for 16 and 32-cylinder, 4-cycle applications programmed with the number of teeth used on the test stand (usually 180) will be needed.
  - M. Altronic CPU-2000 Terminal Program part number CPU-2000.MEM.  
NOTE: Reference form CPU-2000 PI, section 1.3 for computer and peripheral requirements for the Terminal Program.
  - N. A means to elevate CPU-2000 Output Module to a controlled temperature of 150°F. (65°C.).
  - O. A 293030-25 cable to connect the Logic Module to the Output Module.  
NOTE: Altronic Test Unit 791025-1 can provide simulated pickup signals to exercise the CPU-2000 outputs at a fixed firing rate.
  - P. The optional CPU-2000 Diagnostic Module 291105-1 can be adapted using harness 293031 and a 3-conductor cable 593050 as shown in the Test Stand Wiring diagram.

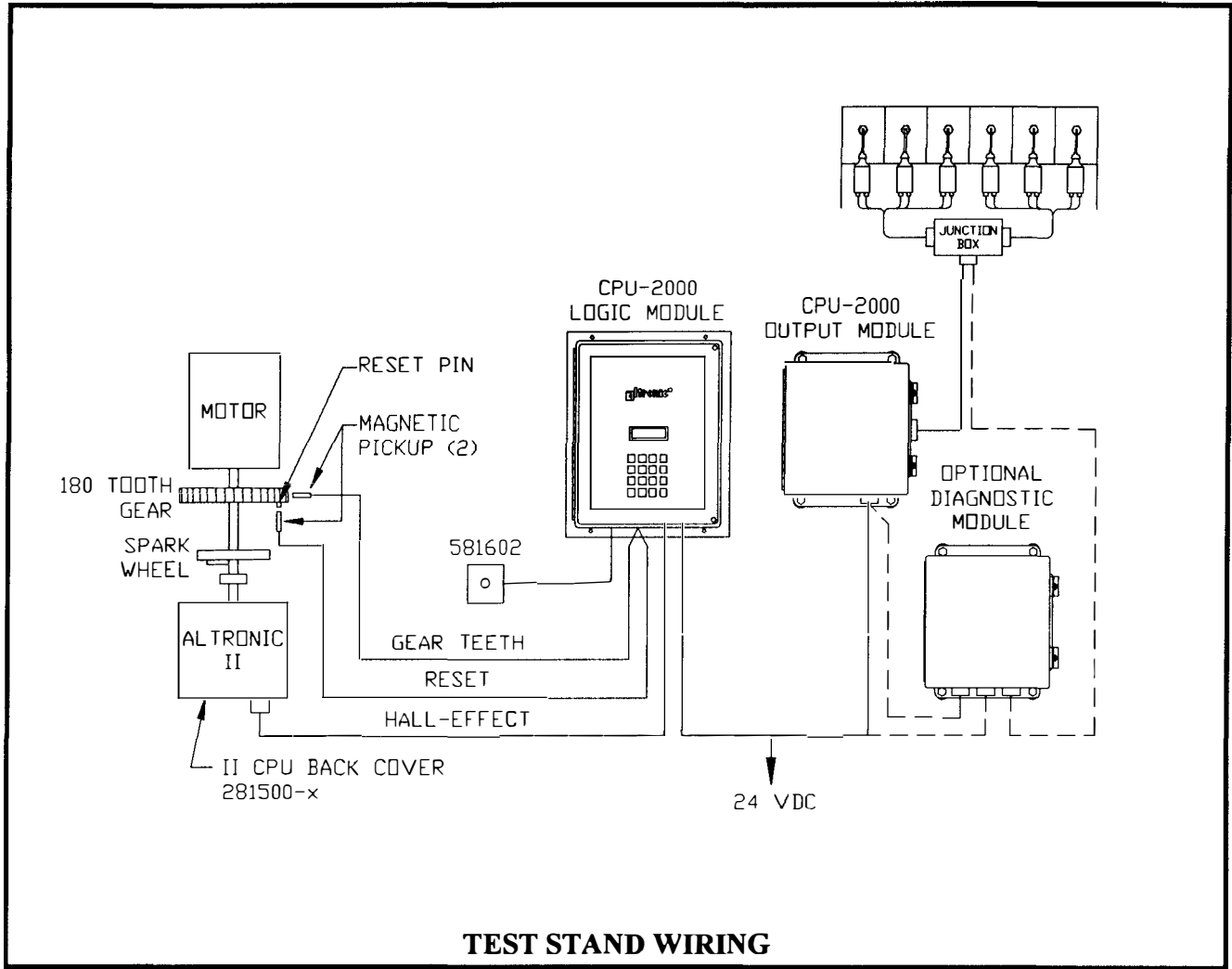

**4-CYCLE PICKUP INPUT WIRING**

CPU-2000 LOGIC INPUT	281500-X 5-PIN CONNECTOR	DESCRIPTION
A (4-cycle pickup)	PIN E	HALL EFFECT OUTPUT
B (4-cycle pickup)	PIN D	HALL EFFECT (+) SUPPLY
C (4-cycle pickup)	PIN C	HALL EFFECT (-) RETURN
	PIN B	* SEE NOTE 1
	PIN A	* SEE NOTE 1

\*Note 1: Connect leads A and B together (shorts the alternator output)

**4.0 TESTING PROCEDURE - CPU-2000 OUTPUT MODULES 291116-1, 291132-1**

- 4.1 VOLTAGE OUTPUT TEST - Connect the Output Module to a test Logic Module. Reference Installation Instructions form CPU-2000 II for correct wiring of the Logic Module. Set Logic Module for energy level 2 (E2). Operate the test stand at 360 RPM leaving the 19-pin connector(s) disconnected. Output voltage is measured from the "P" pin (+) to the "N" pin (-) and from the "P" pin (+) to the "V" pin (-) with an oscilloscope. The output voltage should be 320 ±10 Vdc for both measurements.
- 4.2 OPERATIONAL TEST - With the system completely connected, perform the following tests on the Output Module. It is recommended that these tests be performed with the CPU-2000 Output Module heated to a temperature of 150°F. (65°C.). Tests should be performed using a P4A180.HC memory for 16-output units and a P8A180.HC memory for 32-output models, assuming the test stand uses a 180 tooth gear.

180 TOOTH

GEAR RPM TEST

75 RPM	All outputs fire a 15mm gap.
360 RPM	All outputs fire a 15mm gap.
360 RPM	Each cylinder fires consistently in sequence: Timing as follows starting with output "A" and proceeding in alphabetical sequence: Unit 291116-1: A-B-C-D-E-F-G-H-J-K-L-M-R-S-T-U Unit 291132-1: A1-A2-B1-B2-C1-C2-D1-D2-E1-E2-F1-F2-G1-G2-H1-H2-J1-J2-K1-K2-L1-L2-M1-M2-R1-R2-S1-S2-T1-T2-U1-U2 Note: X1 = upper connector; X2 = lower connector

**5.0 OHMMETER CHECKS**

- 5.1 CPU-2000 OUTPUT MODULE - The following tests should be made using a Simpson Model 260 analog volt-ohmmeter (VOM) set to "ohms". The ohmmeter scale should be set to "R x 10,000". Readings outside the range indicated establish a defective Output Module. A unit passing the ohmmeter tests may still be defective and the full test should be performed using an oscilloscope (see sections 6.0) to confirm correct operation.
- A. Check the resistance with the negative lead of ohmmeter connected to the "N" lead and the positive lead connected to each output pin of the output (top) connector. If ohmmeter reading is less than 250,000 ohms replace the Top Power Board (3-3, 4-3).
  - B. Check the resistance with the negative lead of ohmmeter connected to the "V" lead and the positive lead connected to each output pin of the output (top) connector. If ohmmeter reading is less than 250,000 ohms replace the Top Power Board (3-3, 4-3).
  - C. Check the resistance with the positive lead of ohmmeter connected to the "P" lead and the negative lead connected to each output pin of the output (top) connector. If ohmmeter reading is less than 250,000 ohms replace the Top Power Board (3-3, 4-3).

## 6.0 OSCILLOSCOPE TESTS

6.1 TEST SET-UP - Two 100:1 oscilloscope probes are required. Test speed is 360 RPM. NOTE: The signals being monitored are 290 to 350 volts, negative polarity. It is recommended that these tests be performed with the Output Module heated to a temperature of 150°F. (65°C.).

### 6.2 STORAGE CAPACITOR VOLTAGE PATTERN

- A. The trigger input of the oscilloscope should be connected to the "A" primary coil lead.  
NOTE: This is a 290 to 350 volt, negative polarity signal.
- B. Connect the oscilloscope reading probe to the "N" lead of the output connector to view the "A" side outputs. To view the "B" side outputs connect the oscilloscope probe to the "V" lead. Normal capacitor patterns are shown below.
- C. Peak output voltage for the Output Module is:
  - 290±10 volts for energy level E1,
  - 320±10 volts for energy level E2,
  - 350±10 volts for energy level E3.

### 6.3 MULTI-STRIKE TESTS

- A. Set the unit to MULTI-STRIKE mode via the keypad on the Logic Module.
- B. Connect oscilloscope to the "N" lead and view first set of shutdown pattern firings.
- C. Verify "A" firing is followed by three additional firings and the time between the first and fourth firing is four to five milliseconds (See figure MULTI-STRIKE).
- D. Connect the oscilloscope probe to the "V" lead and repeat step C.

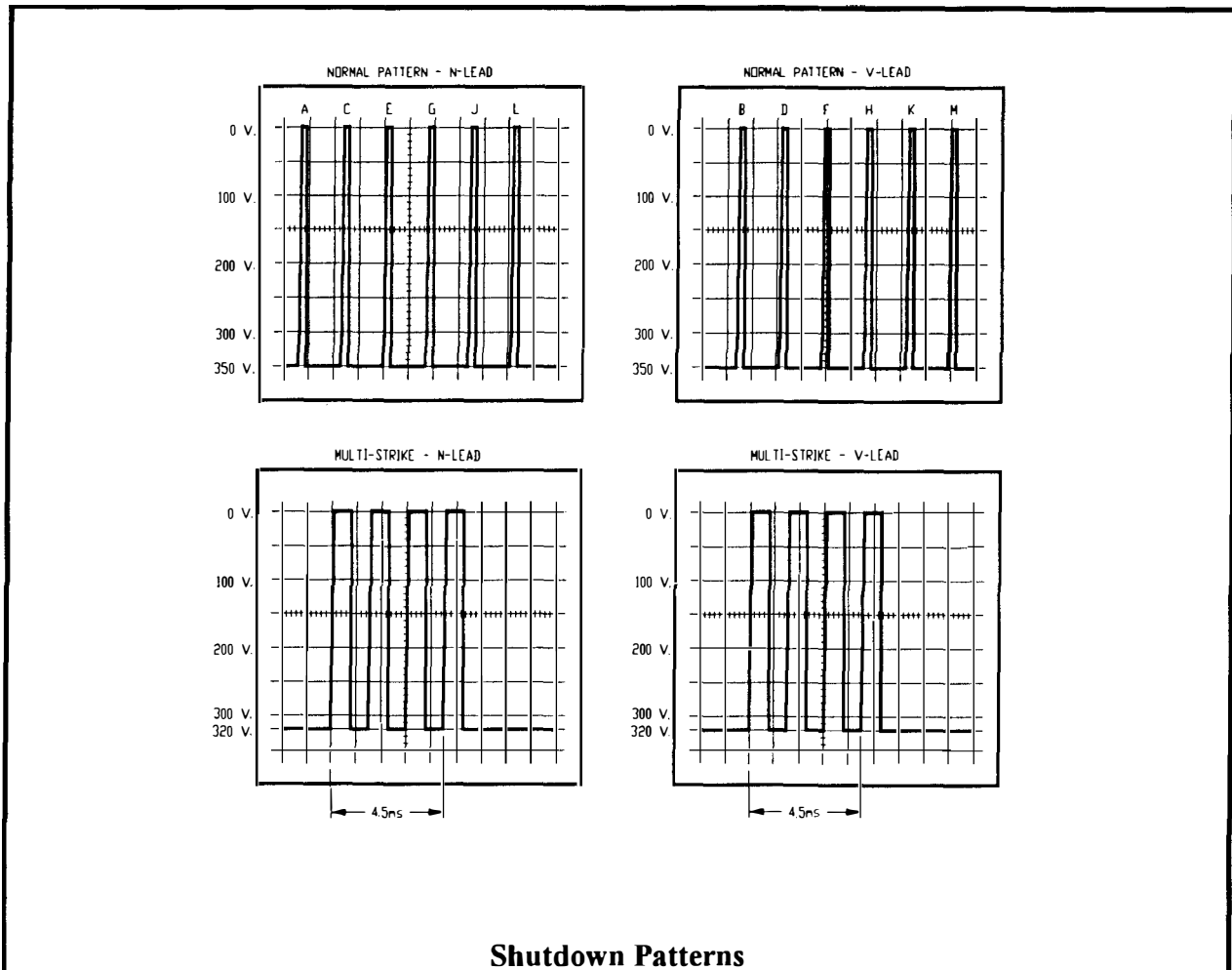



## 7.0 TESTING PROCEDURE - CPU-2000 LOGIC MODULE

7.1 OPERATIONAL TESTS - Connect the Logic Module to a test Output Module known to be operational. Reference Installation Instructions form CPU-2000 II for correct wiring and Operating Instructions form CPU-2000 OI for operation of the Logic Module. Install a test EEPROM with the same number of teeth as the test stand and the same or less than the number of outputs on the test Output Module, or program a blank EEPROM. NOTE: Do not program over the original EEPROM. (A memory code P4A180.HC or a P8A180.HC is recommended for testing). Apply 24 Vdc input power to the unit and run at 360 RPM. Perform the following tests at room temperature.

- A. Assure each output fires in sequence, with no multiple firings and in the correct timing on the spark wheel:

P4A180.HC firing pattern (in degrees):

0 - 45 - 90 - 135 - 180 - 225 - 270 - 315 - 0 - 45 - 90 - 135 - 180 - 225 - 270 - 315

P8A180.HC firing pattern (in degrees):

0 - 22.5 - 45 - 67.5 - 90 - 112.5 - 135 - 157.5 - 180 - 202.5 - 225 - 247.5 - 270 - 292.5 - 315 - 337.5 -  
0 - 22.5 - 45 - 67.5 - 90 - 112.5 - 135 - 157.5 - 180 - 202.5 - 225 - 247.5 - 270 - 292.5 - 315 - 337.5

- B. The display on the CPU-2000 Logic Module should read "FIRING".  
The panel I/O switches should be as follows:  
Fire Confirm Out - *closed*; Shutdown Out - *closed*; Alarm Out - *closed*.
- C. Place Logic Module in Multi-Strike mode and assure outputs are multiple firing (ref. form CPU-2000 OI section 9.2 ). Turn Multi-Strike OFF before continuing the test.
- D. Change the energy level from E1 to E3 and verify the output voltage changes from -290±10 volts to -350±10 volts (reference form CPU-2000 OI, section 9.3).
- E. Ground the Panel I/O Shutdown Input. Ignition firings should immediately cease and the display should read "SHUTDOWN". The panel I/O switches should be as follows:  
Fire Confirm Out - *open*; Shutdown Out - *closed*; Alarm Out - *closed*.

7.2 TIMING TESTS. - The following tests should be performed on the Logic Module to verify proper control of timing (reference form CPU-2000 OI, sections 5.0-8.3).

- A. Enter the TIMING menu and test the GLOBAL RETARD. Vary the global timing and verify the timing changes on the spark wheel and on the display (reference form CPU-2000 OI, section 5.0).
- B. Enter the TIMING menu and test the ONE-STEP RETARD. Ground the miscellaneous input in the Logic Module and assure the timing retards by the one-step retard value (reference CPU-2000 OI, section 6.5).
- C. Vary the 4 to 20 mA loop and assure the timing retards 24 degrees at 20 mA (or other value corresponding to the memory program used).

## 8.0 TESTING PROCEDURE - CPU- 2000 DIAGNOSTIC MODULE

8.1 OPERATIONAL TESTS - Connect the Diagnostic Module to the test Logic and Output Modules as shown in the Test Stand Wiring diagram. Reference Installation Instructions form CPU-2000 II for correct wiring and Operating Instructions form CPU-2000 OI for operation of the Diagnostic Module. Operate the ignition and ENABLE the Diagnostic Module via setup screen. NOTE: The display board EPROM 601707 and logic board MICROPROCESSOR 601747 must be ver2.0 or higher for Diagnostic Module operation. Set the DIAG COUNT FREQ to LO via setup screen. Set the power level to E3S.

- A. Verify RXD and TXD LED's are flashing and RES LED is on solid in the Diagnostic Module.
- B. Short the secondaries of A1, A2 (32-output) or A, B (16-output) coils on the spark rack. NOTE: the coils should be 291001 Altronic coils and wired one per output. The INST values should be 85 +/- 15 counts for each of the two coils.

## 9.0 TROUBLESHOOTING

Perform all tests at a test stand speed of 360 RPM with a 4-cycle test memory. The following tests assume an adequate 12-24 Vdc power source and properly installed magnetic and Hall-effect pickups.

9.1 POWER MODULE - The following tests are to be performed with a known good Logic Module.

PROBLEM	TEST	TEST INDICATION	CORRECTIVE ACTION (Figs. 3,4)
No output	Section 4.1	Low voltage *	Replace bottom power board (2).
One output does not fire	Section 4.2/6.2	Missing discharge on stand or scope	Replace top power board (3).
Only one output fires or fires consistently	Section 4.2/6.2	Only one spark gap is firing	Replace top power board (3).
No Multi-Strike function	Section 6.3	Outputs do not have four firings, 4-5 milliseconds apart	Measure voltage at pin 10 of Vss of the ribbon cable on top power board. If voltage is 5V. in Multi-Strike mode, replace top power board. If voltage is 4V. or less, replace bottom power board.

\* Logic Module display will read LOW OUTPUT VOLTS ON A (or B) SIDE (reference section 10.6 of CPU-2000 OI).

\*\* Logic Module display will read PRIMARY FAULT (reference section 10.6 of CPU-2000 OI).

9.2 LOGIC MODULE - The following tests are to be performed with a known good Output Module. The tests assume a fully functional test stand.

PROBLEM	TEST	TEST INDICATION	CORRECTIVE ACTION (see Fig. 2)
Timing varies	Section 7.1	Timing other than as shown	Replace logic board (9).
No function from keypad	Section 7.1/7.2	Pressing keypad has no effect	Assure keypad is plugged in to display board. Replace keypad (2). ***
No timing change from 4-20 mA input	Section 7.2	Timing does not change when 4-20 mA input is varied	Replace logic board (9).

\*\*\* May indicate a defective display or logic board.

9.3 LOGIC MODULE DIAGNOSTICS MESSAGES - If any of the following diagnostic messages appear when testing the Logic Module then replace the logic board.

- A. GT PICKUP FAULT MISSING PULSES
- B. RS PICKUP FAULT MISSING PULSES
- C. HE PICKUP FAULT MISSING // NO-SYNC
- D. RING-GEAR FAULT xxx TEETH READ where xxx is not equal to the number of teeth on the test stand.
- E. BOTTOM BOARD  $\mu$ P CHECKSUM FAILED
- F. CURRENT LOOP OUT OF RANGE

9.4 DIAGNOSTIC MODULE - The following tests are to be performed with known good Logic and Output Modules.

PROBLEM	TEST	TEST INDICATION	CORRECTIVE ACTION (see Fig. 5)
No function from Module	Section 8.1	Missing or incorrect data (counts).	Replace circuit board assembly (5).

## **10.0 BOARD REPLACEMENT PROCEDURE - OUTPUT MODULE TOP POWER BOARD**

### **10.1 DISASSEMBLY PROCEDURE (refer to figure 3 or 4)**

- A. Remove four screws (8) from top power board (3).
- B. Remove the screws (2f) from the output connector(s) and push connector back inside the box.
- C. Unplug the 4-pin ribbon cable from the top board and the 15-pin ribbon cable from the bottom power board (2).
- D. The top power board can now be removed from the box.

### **10.2 ASSEMBLY PROCEDURE (refer to figure 3 or 4)**

- A. Check the condition of the connector gasket(s) (3a) and replace as necessary.
- B. Plug 15-pin ribbon connector into the socket on the bottom power board (2).
- C. Place top power board (3) in Output Module box.
- D. Install connector gasket(s) (3a) to connector(s) and insert the connector(s) into the box and orient the key(s) toward bottom of box. Install the four screws (2f) and lockwashers (2e) for each connector and tighten securely.
- E. Plug the 4-pin ribbon cable into the connector on the top power board.
- F. Secure the top power board with four screws (8).
- G. Retest Output Module per sections 4.0 and 6.0 to verify correct operation.

## **11.0 BOARD REPLACEMENT PROCEDURE - OUTPUT MODULE BOTTOM POWER BOARD**

### **11.1 DISASSEMBLY PROCEDURE (refer to figure 3 or 4)**

- A. Remove top power board (refer to section 9.1).
- B. Remove four screws (2f) from connector on side of Output Module box and push connector into box.
- C. Remove the eight screws (2b, 5) from the bottom of the Output Module box.
- D. Remove the four standoffs (7) from the top of the bottom power board.
- E. The bottom power board (2) can now be removed from the box.

### **11.2 ASSEMBLY PROCEDURE (refer to figure 3 or 4)**

- A. Check the condition of the connector gasket (3a) and replace as necessary.
- B. Examine the condition of the four insulators (2a) on the transistors on the bottom of the board and replace if damaged.
- C. Place bottom power board (2) in box.
- D. Install the four standoffs (7) to secure board in box. Do not tighten.
- E. Install eight NEW screws (2b, 5) in bottom of Output Module box. Tighten securely.
- F. Tighten four standoffs securely.
- G. Install the connector gasket(s) (3a) and insert connector(s) into the box and orient the key(s) toward bottom of box. Install the four screws (2f) and lockwashers (2e) for each connector and tighten securely.
- H. Install top power board (refer to section 9.3).
- I. Retest Output module per sections 4.0 and 6.0 to verify correct operation.

## **12.0 BOARD REPLACEMENT PROCEDURE - LOGIC MODULE DISPLAY BOARD**

### **12.1 DISASSEMBLY PROCEDURE (refer to figure 2)**

- A. Unplug keypad cable.
- B. Remove four screws (7) from the shield board (13) on the display board (12) and remove shield board.
- C. Remove ribbon cable.
- D. Remove four standoffs (8) and remove display board (12).

### **12.2 ASSEMBLY PROCEDURE (refer to figure 2)**

- A. Replace display board (12) and secure with four standoffs (8).
- B. Connect ribbon cable to display board.
- C. Replace shield board with notch (13) over the ribbon cable. Tighten 4 screws (7).
- D. Plug keypad cable into display board.
- E. Retest Logic module per section 7.0 to verify correct operation.

## **13.0 BOARD REPLACEMENT PROCEDURE - LOGIC MODULE LOGIC BOARD**

### **13.1 DISASSEMBLY PROCEDURE (refer to figure 2)**

- A. Remove four screws (7) and remove shield board (10).
- B. Remove two screws (7) and five standoffs (8) and remove the logic board (9).
- C. Disconnect ribbon cable from the logic board.

### **13.2 ASSEMBLY PROCEDURE (refer to figure 2)**

- A. Connect ribbon cable to logic board (9).
- B. Put logic board in Logic Module box and secure with top screws (7) and five standoffs (8).
- C. Replace shield board (10) and secure with four screws (7).
- D. Retest Logic Module per section 7.0 to verify correct operation.

## **14.0 BOARD REPLACEMENT PROCEDURE - DIAGNOSTIC MODULE**

### **14.1 DISASSEMBLY PROCEDURE (refer to figure 5)**

- A. Remove sixteen screws (9) from four connectors and push connectors into box.
- B. Remove four screws (13) from circuit board.
- C. The circuit board assembly can now be removed from the enclosure.

### **14.2 ASSEMBLY PROCEDURE (refer to figure 5)**

- A. Check the condition of the connector gaskets (6, 7, 8) and replace as necessary.
- B. Place circuit board assembly (5) in enclosure (1).
- C. Install and securely tighten four screws (13) to secure board in enclosure.
- D. Install connector gaskets and install connectors into enclosure with keys oriented toward the bottom of the box.
- E. Install sixteen new screws (9) into connectors and tighten securely.
- F. Retest the Diagnostic Module per sections 4.0, 7.0 and 8.0 to verify correct operation.