

**REQUIRED ITEMS:**

**A: CPU-95 IGNITION MODULE, 1 PER SYSTEM**

PART NO.	DESCRIPTION
791950-8	Ignition Module, 8 outputs, single capacitor
791950-16	Ignition Module, 16 outputs, single capacitor
791950-18	Ignition Module, 18 outputs, single capacitor
791952-18	Ignition Module, 18 outputs, dual capacitor
791952-20	Ignition Module, 20 outputs, dual capacitor
791958-16	Ignition Module, 16 outputs, Varispark™ extended spark duration
791963-16A	Ignition module, 16 outputs, Enhanced Varispark™, Directed Energy Ignition System
791963-16E	Ignition module, 16 outputs, Enhanced Varispark™, Directed Energy Ignition System, Cat EIS (coils under the valve cover)

**NOTE:** Listings show recommended selection; where listing indicates model 791958-16, model 791950-xx was previously specified and may also be used.

**MEMORY PART NO. CODE** (see application listings). Example: H4A230.FS012#005

DESIGNATOR	DESCRIPTION
H	Letter in alphabet corresponding to no. of engine cylinders: B=2, C=3, D=4, E=5, F=6, G=7, H=8, I=9, J=10, L=12, N=14, P=16, R=18
4	Engine stroke-cycle: 2 = 2-cycle, 4 = 4-cycle
A	Altronic firing pattern code: A = even firing pattern, Other letters = odd firing pattern
230	No. of sensed teeth or holes: 230 = 230 teeth or holes
F	Memory series code: F = CPU-95, Ignition Modules 791950-xx, 791952-xx, 791958-xx G = CPU-95, Ignition Module 791955-16
S	Timing curve code: A = 48 degree retard for 4-20 mA input, 3 degrees retard default timing B = 36 degree retard for 4-20 mA input, 3 degrees retard default timing C = 24 degree retard for 4-20 mA input, 3 degrees retard default timing D = 16 degree retard for 4-20 mA input, 3 degrees retard default timing E = 8 degree retard for 4-20 mA input, 3 degrees retard default timing N = special range vs. 4-20 mA or RPM, non-factory programmed S = special range vs. 4-20 mA or RPM, factory programmed X = no timing curve programmed
012	Special timing curve version number
#005	Feature code (add numbers chosen; only one choice permitted per feature): 001 = 1-step retard when misc. input is grounded 016 = 1-step retard when rpm is less than 250 002 = Max. energy when misc. input is grounded 032 = Max. energy when rpm is less than 250 004 = Extended firing when misc. input is grounded 064 = Extended firing when rpm is less than 250 Example: 005 = feature 001 + feature 004

## CPU-95/CPU-95EVS DIGITAL IGNITION SYSTEM

Second Example: L4A180.FC#080	12-cylinder, 4-cycle 36° firing pattern (J2A) 180 sensed teeth 24° timing range for 4-20mA Feature codes 016 and 064 selected
----------------------------------	---

### REQUIRED ITEMS:

#### B: CPU-95 DISPLAY MODULE, 1 PER SYSTEM

PART NO.	DESCRIPTION
791909-1	Display Module, enhanced

#### C: OUTPUT HARNESS

##### CPU-95 UNIT TO J-BOX OR IGNITION COILS, 1 PER SYSTEM (2 WITH 791952-20)

PART NO.	DESCRIPTION
793012-8	Harness, unshielded, 180° connector, 180" leads, 8 outputs
793012-12	Harness, unshielded, 180° connector, 180" leads, 12 outputs
793012-16	Harness, unshielded, 180° connector, 180" leads, 16 outputs
793015-8	Harness, shielded, 180° connector, 48" conduit, 180" leads, 8 outputs
793015-18	Harness, shielded, 180° connector, 48" conduit, 180" leads, 18 outputs
793022-8	Harness, shielded, 180° connector, 84" conduit, 180" leads, 8 outputs
793022-18	Harness, shielded, 180° connector, 84" conduit, 180" leads, 18 outputs
293023-9A	Harness, shielded, 90° connector, 48" conduit, 72" leads, 9 outputs
293023-16	Harness, shielded, 90° connector, 48" conduit, 72" leads, 18 outputs
293026-9A	Harness, shielded, 90° connector, 84" conduit, 120" leads, 9 outputs
293026-16	Harness, shielded, 90° connector, 84" conduit, 120" leads, 18 outputs

NOTE: Above shielded harnesses are CSA certified for Class I, Division 2, Group D hazardous locations when used with other applicable CSA-certified Altronic components.

#### D: MAGNETIC PICKUP, 2 PER SYSTEM

PART NO.	DESCRIPTION
691118-1	Magnetic Pickup, 5/8"-18 thread x 1.75" threaded body length
691118-2	Magnetic Pickup, 5/8"-18 thread x 2.50" threaded body length
691118-3	Magnetic Pickup, 5/8"-18 thread x 3.00" threaded body length
691118-4	Magnetic Pickup, 5/8"-18 thread x 4.50" threaded body length
691118-6	Magnetic Pickup, 5/8"-18 thread x 6.00" threaded body length

#### E: CABLE ASSEMBLY, MAGNETIC PICKUP, 2 PER SYSTEM

PART NO.	DESCRIPTION
693104-1	Pickup Cable, unshielded, 180° connector, 10 ft. cable
693104-2	Pickup Cable, unshielded, 180° connector, 20 ft. cable
693104-3	Pickup Cable, unshielded, 180° connector, 30 ft. cable
693104-4	Pickup Cable, unshielded, 180° connector, 40 ft. cable
693104-5	Pickup Cable, unshielded, 180° connector, 50 ft. cable
593048-L	Pickup Cable, shielded, 180° connector, L" conduit, 50 ft. cable L = 12", 18", 24", 36", 48", 72", 96", 120"
593054-L	Pickup Cable, shielded, 90° connector, L" conduit, 50 ft. cable L = 12", 18", 24", 36", 48", 72", 96", 120"

## CPU-95/CPU-95EVS DIGITAL IGNITION SYSTEM

### E: CABLE ASSEMBLY, MAGNETIC PICKUP (CONTINUED)

PART NO.	DESCRIPTION
593048A-L	Pickup Cable, shielded, 180°connector, L" conduit, 100 ft. cable L = 24", 48", 72", 96"
593054A-L	Pickup Cable, shielded, 90°connector, L" conduit, 100 ft. cable L = 24", 48", 72", 96"

NOTE: Above shielded cables are CSA certified for Class I, Divison 2, Group D hazardous locations when used with other applicable CSA-certified Altronic components.

### F: CYCLE TRIGGER (4-CYCLE ENGINES ONLY), 1 FROM EACH CATEGORY BELOW, PER SYSTEM

PART NO.	DESCRIPTION
<i>Trigger Magnet (camshaft mount):</i>	
260604	Trigger Magnet, 3/4" dia. x 8 mm thread (max. rotating circle is 15" dia.)
260605	Trigger Magnet, 3/4" hex x 8 mm thread (max. rotating circle is 15" dia.)
720002	Trigger Magnet, 3/8" hex x 8 mm thread (max. rotating circle is 6" dia.)
790111-1	Trigger Magnet disc, 5.0" dia.
<i>Hall-effect Pickup:</i>	
591014-2	Hall-effect Pickup, 5/8"-18 thread x 2.5" threaded body length
591014-4	Hall-effect Pickup, 5/8"-18 thread x 4.0" threaded body length
<i>Pickup Cable:</i>	
593050	Pickup Cable, unshielded, 180° connector, 48" conduit, 25 ft. cable
593052-L	Pickup Cable, shielded, 180° connector, L" conduit, 25 ft. cable L = 6", 12", 18", 24", 36", 48", 72", 96"
593057-L	Pickup Cable, shielded, 90° connector, L" conduit, 25 ft. cable L = 6", 12", 18", 24", 36", 48", 72", 96"

NOTE: Above shielded cables are CSA certified for Class I, Divison 2, Group D hazardous locations when used with other applicable CSA-certified Altronic components.

### G: IGNITION COILS, 1 PER SPARK PLUG

PART NO.	DESCRIPTION
501061	Unshielded Coil, standard duration
591010*	Unshielded Coil, long duration
501061-S	Shielded Coil, standard duration
591010-S*	Shielded Coil, long duration
591018	Flange Coil, standard duration
591012*	Flange Coil, long duration
591007	Integral Coil, 1"-20 thread x 5.6" length
591011A	Integral Coil, 13/16"-20 thread x 6.1" length
591011B	Integral Coil, 13/16"-20 thread x 10.8" length

\* Use coil 591010, 591010-S or 591012 with Ignition Module 791958-16.

### H: -185V DC-DC POWER SUPPLY, 1 PER SYSTEM (USE 1 WITH 791963-XXX ONLY)

PART NO.	DESCRIPTION
791911	DC to DC power supply. 24V to -185V

## CPU-95/CPU-95EVS DIGITAL IGNITION SYSTEM

---

### REQUIRED ITEMS:

#### I: OUTPUT HARNESS CPU-95EVS IGNITION UNIT TO J-BOX OR DC-DC POWER SUPPLY (USE 1 WITH 791963-XX ONLY)

PART NO.	DESCRIPTION
393023-1	unshielded 180° 72" 16AWG
393023-2	unshielded 180° 180" 16AWG
393011-1	unshielded 90° 72" 16AWG
393011-2	unshielded 90° 180" 16AWG
393025-2	shielded 19" overall 72" 16AWG 180°
393013-1	shielded 48" overall 72" 16AWG 90°
393013-2	shielded 48" overall 180" 16AWG 90°
393013-4	shielded 20" overall 60" 16AWG 90°
393013-5	shielded 120" overall 300" 16AWG 90°
393013-8	shielded 60" overall 72" 16AWG 90°
393013-12	shielded 26" overall 48" 16AWG 90°
393013-13	shielded 30" overall 48" 16AWG 90°
393013-14	shielded 30" overall 80" 16AWG 90°

### OPTIONAL ITEMS:

#### J: MOUNTING KITS FOR DC TO DC POWER SUPPLY

PART NO.	DESCRIPTION
720011-1	Mounting bars and screws for non-vibration mounting environments
720011-2	T-nuts, bolts, and lock washers for non-vibration mounting environments
720011-3	Mounting bars, screws, and shock mounts for vibration mounting environments

#### K: DETONATION MONITORING

PART NO.	DESCRIPTION
DET-1620 (12)	Detonation monitoring device for use with CPU-95EVS system

#### L: DETONATION MONITOR ADAPTER

PART NO.	DESCRIPTION
691117-1	Mandatory adapter for S.D. Lead and G-lead to DET monitor

# CPU-95/CPU-95EVS DIGITAL IGNITION SYSTEM

## CPU-95EVS BASIC SYSTEM LAYOUT

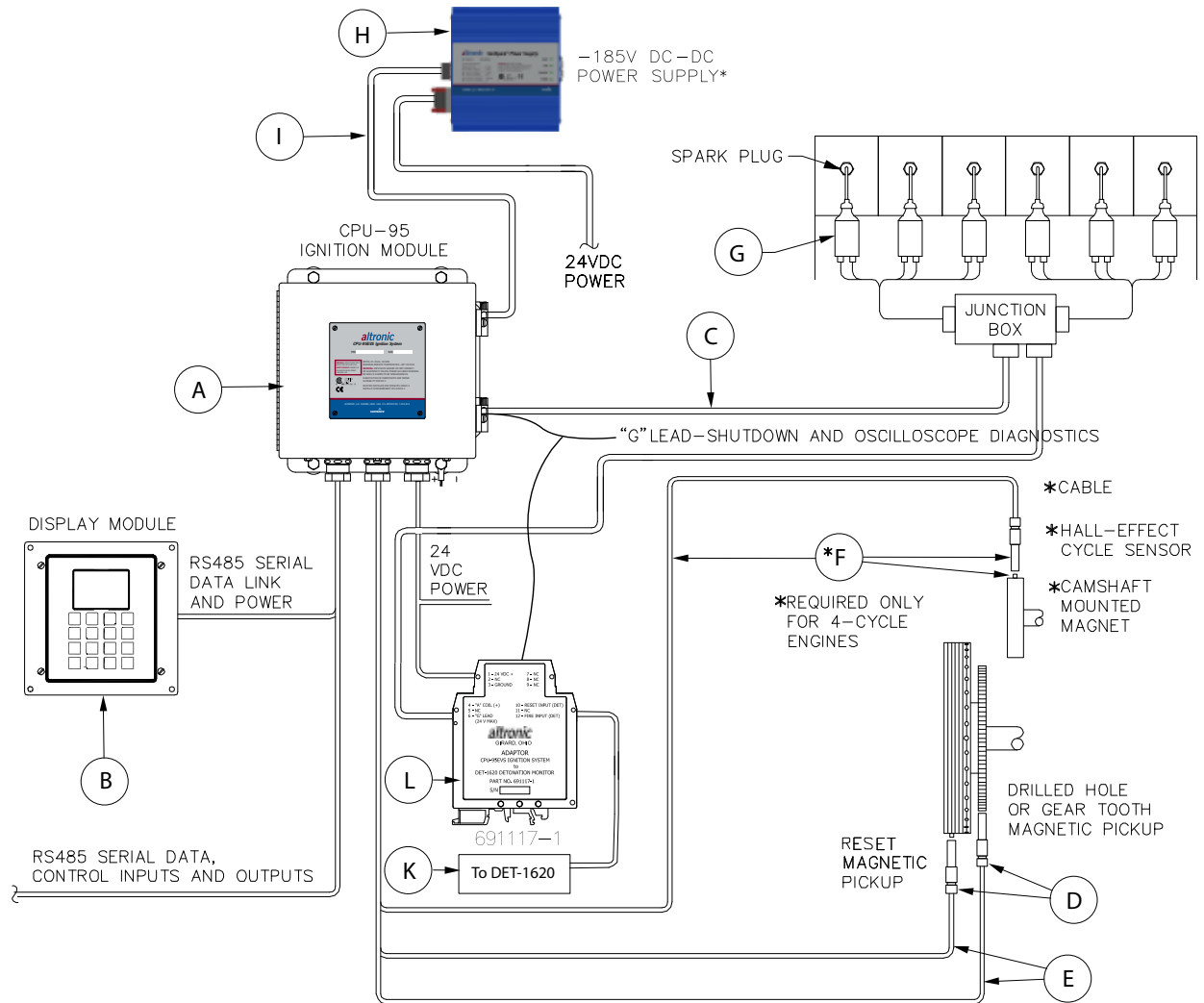

## CPU-95/CPU-95EVS DIGITAL IGNITION SYSTEM FOR USE WITH CAT EIS COILS AND EBC

### REQUIRED ITEMS:

#### A: CPU-95 IGNITION MODULE, 1 PER SYSTEM, FOR USE WITH CAT EIS COILS AND EBC

PART NO.	DESCRIPTION
791963-8E CAT EIS	Ignition Module, 8 outputs, Enhanced Varispark, EIS coil
791963-16E CAT EIS	Ignition Module, 16 outputs, Enhanced Varispark, EIS coil

NOTE: 791963-XXE can only be used with EIS coils. Damage may occur if utilized with standard blue or red coils.

MEMORY PART NO. CODE (see application listings). Example: H4A230.FS012#005

DESIGNATOR	DESCRIPTION
H	Letter in alphabet corresponding to no. of engine cylinders: B=2, C=3, D=4, E=5, F=6, G=7, H=8, I=9, J=10, L=12, N=14, P=16, R=18
4	Engine stroke-cycle: 2 = 2-cycle, 4 = 4-cycle
A	Altronic firing pattern code: A = even firing pattern, Other letters = odd firing pattern
230	No. of sensed teeth or holes: 230 = 230 teeth or holes
F	Memory series code: F = CPU-95, Ignition Modules 791950-xx, 791952-xx, 791958-xx, 791963-16E Cat EIS (coils under the valve cover) G = CPU-95, Ignition Module 791955-16
S	Timing curve code: A = 48 degree retard for 4-20 mA input, 3 degrees retard default timing B = 36 degree retard for 4-20 mA input, 3 degrees retard default timing C = 24 degree retard for 4-20 mA input, 3 degrees retard default timing D = 16 degree retard for 4-20 mA input, 3 degrees retard default timing E = 8 degree retard for 4-20 mA input, 3 degrees retard default timing N = special range vs. 4-20 mA or RPM, non-factory programmed S = special range vs. 4-20 mA or RPM, factory programmed X = no timing curve programmed
012	Special timing curve version number
#005	Feature code (add numbers chosen; only one choice permitted per feature): 001 = 1-step retard when misc. input is grounded 016 = 1-step retard when rpm is less than 250 002 = Max. energy when misc. input is grounded 032 = Max. energy when rpm is less than 250 004 = Extended firing when misc. input is grounded 064 = Extended firing when rpm is less than 250 Example: 005 = feature 001 + feature 004
2nd example: L4A180.FC#080	12-cylinder, 4-cycle 36° firing pattern (J2A) 180 sensed teeth 24° timing range for 4-20mA Feature codes 016 and 064 selected

#### B: CPU-95 DISPLAY MODULE, 1 PER SYSTEM, FOR USE WITH CAT EIS COILS AND EBC

PART NO.	DESCRIPTION
791902-1	Display Module, standard
791902-1S	Display Module, no test function
791908-1	Display Module, dual port
791909-1*	Display Module, enhanced

\* Recommended for new installations

## CPU-95/CPU-95EVS DIGITAL IGNITION SYSTEM FOR USE WITH CAT EIS COILS AND EBC

### C: OUTPUT HARNESS

#### CPU-95EVS UNIT TO EZ-RAIL JUNCTION BOX, FOR USE WITH CAT EIS COILS AND EBC

PART NO.	DESCRIPTION
793102-24	HARNESS, 19 PIN, 90° CONNECTOR, CONDUIT, 90° CONNECTOR, 24"
793102-36	Harness, 19 Pin, 90° Connector, Conduit, 90° Connector, 36"
793102-48	Harness, 19 Pin, 90° Connector, Conduit, 90° Connector, 48"
793102-60	Harness, 19 Pin, 90° Connector, Conduit, 90° Connector, 60"
793102-72	Harness, 19 Pin, 90° Connector, Conduit, 90° Connector, 72"
793102-96	Harness, 19 Pin, 90° Connector, Conduit, 90° Connector, 96"
793102-120	Harness, 19 Pin, 90° Connector, Conduit, 90° Connector, 120"
793102-144	Harness, 19 Pin, 90° Connector, Conduit, 90° Connector, 144"
793102-180	Harness, 19 Pin, 90° Connector, Conduit, 90° Connector, 180"
793102-240	Harness, 19 Pin, 90° Connector, Conduit, 90° Connector, 240"
793101-24	Harness, 19 Pin, 90° Connector, Conduit, 180° Connector, 24"
793101-36	Harness, 19 Pin, 90° Connector, Conduit, 180° Connector, 36"
793101-48	Harness, 19 Pin, 90° Connector, Conduit, 180° Connector, 48"
793101-60	Harness, 19 Pin, 90° Connector, Conduit, 180° Connector, 60"
793101-72	Harness, 19 Pin, 90° Connector, Conduit, 180° Connector, 72"
793101-96	Harness, 19 Pin, 90° Connector, Conduit, 180° Connector, 96"
793101-120	Harness, 19 Pin, 90° Connector, Conduit, 180° Connector, 120"
793101-144	Harness, 19 Pin, 90° Connector, Conduit, 180° Connector, 144"
793101-180	Harness, 19 Pin, 90° Connector, Conduit, 180° Connector, 180"
793101-240	Harness, 19 Pin, 90° Connector, Conduit, 180° Connector, 240"

### D: EZ-RAIL JUNCTION BOX, FOR USE WITH CAT EIS COILS AND EBC

PART NO.	DESCRIPTION
593500-101	EZ-Rail J-Box, 19 Pin Connectors, Outputs 1 to 1, Timing Indicator

### E: OUTPUT HARNESS REQUIRED\*

#### EZ RAIL J-BOX TO ENGINE BLOCK CONNECTOR (EBC)

PART NO.	DESCRIPTION
593922-36A	Harness, CAT 3508 Engine Block Connector (Ebc), 90° Connector, Conduit, 90° Connector, 36"
593922-60A	Harness, CAT 3508 Engine Block Connector (Ebc), 90° Connector, Conduit, 90° Connector, 60"
593922-72A	Harness, CAT 3508 Engine Block Connector (Ebc), 90° Connector, Conduit, 90° Connector, 72"
593922-96A	Harness, CAT 3508 Engine Block Connector (Ebc), 90° Connector, Conduit, 90° Connector, 96"
593922-120A	Harness, CAT 3508 Engine Block Connector (Ebc), 90° Connector, Conduit, 90° Connector, 120"
593922-144A	Harness, CAT 3508 Engine Block Connector (Ebc), 90° Connector, Conduit, 90° Connector, 144"
593922-180A	Harness, CAT 3508 Engine Block Connector (Ebc), 90° Connector, Conduit, 90° Connector, 180"
593922-36B	Harness, CAT 3512 Engine Block Connector (Ebc), 90° Connector, Conduit, 90° Connector, 36"
593922-60B	Harness, CAT 3512 Engine Block Connector (Ebc), 90° Connector, Conduit, 90° Connector, 60"
593922-72B	Harness, CAT 3512 Engine Block Connector (Ebc), 90° Connector, Conduit, 90° Connector, 72"
593922-96B	Harness, CAT 3512 Engine Block Connector (Ebc), 90° Connector, Conduit, 90° Connector, 96"
593922-120B	Harness, CAT 3512 Engine Block Connector (Ebc), 90° Connector, Conduit, 90° Connector, 120"

## CPU-95/CPU-95EVS DIGITAL IGNITION SYSTEM FOR USE WITH CAT EIS COILS AND EBC

### E: OUTPUT HARNESS REQUIRED\* (CONTINUED)

PART NO.	DESCRIPTION
593922-144B	Harness, CAT 3512 Engine Block Connector (Ebc), 90° Connector, Conduit, 90° Connector, 144"
593922-180B	Harness, CAT 3512 Engine Block Connector (Ebc), 90° Connector, Conduit, 90° Connector, 180"
593922-36C	Harness, CAT 3516 Engine Block Connector (Ebc), 90° Connector, Conduit, 90° Connector, 36"
593922-60C	Harness, CAT 3516 Engine Block Connector (Ebc), 90° Connector, Conduit, 90° Connector, 60"
593922-72C	Harness, CAT 3516 Engine Block Connector (Ebc), 90° Connector, Conduit, 90° Connector, 72"
593922-96C	Harness, CAT 3516 Engine Block Connector (Ebc), 90° Connector, Conduit, 90° Connector, 96"
593922-120C	Harness, CAT 3516 Engine Block Connector (Ebc), 90° Connector, Conduit, 90° Connector, 120"
593922-144C	Harness, CAT 3516 Engine Block Connector (Ebc), 90° Connector, Conduit, 90° Connector, 144"
593922-180C	Harness, CAT 3516 Engine Block Connector (Ebc), 90° Connector, Conduit, 90° Connector, 180"

\* 593922 Harness must be used for proper operation of the system

\* 593922 Engine harness is designed to take care of the decoded firing order

\* CPU-95EVS is a positive ground ignition; harness is designed to manage the series diode in the coil

### F: MAGNETIC PICKUP, 2 PER SYSTEM

PART NO.	DESCRIPTION
691118-1	Magnetic Pickup, 5/8"-18 thread x 1.75" threaded body length
691118-2	Magnetic Pickup, 5/8"-18 thread x 2.50" threaded body length
691118-3	Magnetic Pickup, 5/8"-18 thread x 3.00" threaded body length
691118-4	Magnetic Pickup, 5/8"-18 thread x 4.50" threaded body length
691118-6	Magnetic Pickup, 5/8"-18 thread x 6.00" threaded body length

### G: CABLE ASSEMBLY, MAGNETIC PICKUP, 2 PER SYSTEM

PART NO.	DESCRIPTION
693104-1	Pickup Cable, unshielded, 180° connector, 10 ft. cable
693104-2	Pickup Cable, unshielded, 180° connector, 20 ft. cable
693104-3	Pickup Cable, unshielded, 180° connector, 30 ft. cable
693104-4	Pickup Cable, unshielded, 180° connector, 40 ft. cable
693104-5	Pickup Cable, unshielded, 180° connector, 50 ft. cable
593048-L	Pickup Cable, shielded, 180° connector, L" conduit, 50 ft. cable L = 12", 18", 24", 36", 48", 72", 96", 120"
593054-L	Pickup Cable, shielded, 90° connector, L" conduit, 50 ft. cable L = 12", 18", 24", 36", 48", 72", 96", 120"
593048A-L	Pickup Cable, shielded, 180° connector, L" conduit, 100 ft. cable L = 24", 48", 72", 96"
593054A-L	Pickup Cable, shielded, 90° connector, L" conduit, 100 ft. cable L = 24", 48", 72", 96"

NOTE: Above shielded cables are CSA certified for Class I, Division 2, Group D hazardous locations when used with other applicable CSA-certified Altronic components.



## CPU-95/CPU-95EVS DIGITAL IGNITION SYSTEM FOR USE WITH CAT EIS COILS AND EBC

### H: CYCLE TRIGGER (4-CYCLE ENGINES ONLY), 1 FROM EACH CATEGORY BELOW, PER SYSTEM

PART NO.	DESCRIPTION
<i>Trigger Magnet (camshaft mount):</i>	
260604	Trigger Magnet, 3/4" dia. x 8 mm thread (max. rotating circle is 15" dia.)
260605	Trigger Magnet, 3/4" hex x 8 mm thread (max. rotating circle is 15" dia.)
720002	Trigger Magnet, 3/8" hex x 8 mm thread (max. rotating circle is 6" dia.)
790111-1	Trigger Magnet disc, 5.0" dia.
<i>Hall-effect Pickup:</i>	
591014-2	Hall-effect Pickup, 5/8"-18 thread x 2.5" threaded body length
591014-4	Hall-effect Pickup, 5/8"-18 thread x 4.0" threaded body length
<i>Pickup Cable:</i>	
593050	Pickup Cable, unshielded, 180° connector, 48" conduit, 25 ft. cable
593052-L	Pickup Cable, shielded, 180° connector, L' conduit, 25 ft. cable L = 6", 12", 18", 24", 36", 48", 72", 96"
593057-L	Pickup Cable, shielded, 90° connector, L' conduit, 25 ft. cable L = 6", 12", 18", 24", 36", 48", 72", 96"

NOTE: Above shielded cables are CSA certified for Class I, Division 2, Group D hazardous locations when used with other applicable CSA-certified Altronic components.

### I: IGNITION COILS, 1 PER SPARK PLUG (USE 1 WITH 791963-XX ONLY)

The EIS version of the CPU-95EVS can only be used with the eis coils that are housed under the valve cover. Using this system with any standard coil will result in ignition damage.

### J: -185V DC-DC POWER SUPPLY, 1 PER SYSTEM (USE 1 WITH 791963-XXX ONLY)

PART NO.	DESCRIPTION
791911	DC to DC power supply. 24V to -185V

### K: OUTPUT HARNESS CPU-95EVS IGNITION UNIT TO J-BOX OR DC-DC POWER SUPPLY (USE 1 WITH 791963-XX ONLY)

PART NO.	DESCRIPTION
393023-1	unshielded 180° 72" 16AWG
393023-2	unshielded 180° 180" 16AWG
393011-1	unshielded 90° 72" 16AWG
393011-2	unshielded 90° 180" 16AWG
393025-2	shielded 19" overall 72" 16AWG 180°
393013-1	shielded 48" overall 72" 16AWG 90°
393013-2	shielded 48" overall 180" 16AWG 90°
393013-4	shielded 20" overall 60" 16AWG 90°
393013-5	shielded 120" overall 300" 16AWG 90°
393013-8	shielded 60" overall 72" 16AWG 90°
393013-12	shielded 26" overall 48" 16AWG 90°
393013-13	shielded 30" overall 48" 16AWG 90°
393013-14	shielded 30" overall 80" 16AWG 90°

## CPU-95/CPU-95EVS DIGITAL IGNITION SYSTEM FOR USE WITH CAT EIS COILS AND EBC

### OPTIONAL ITEMS:

#### L: MOUNTING KITS FOR DC TO DC POWER SUPPLY

PART NO.	DESCRIPTION
720011-1	Mounting bars and screws for non-vibration mounting environments
720011-2	T-nuts, bolts, and lock washers for non-vibration mounting environments
720011-3	Mounting bars, screws, and shock mounts for vibration mounting environments

#### M: DETONATION MONITORING

PART NO.	DESCRIPTION
DET-1620 (12)	Detonation monitoring device for use with CPU-95EVS system

#### N: DETONATION MONITOR ADAPTER

PART NO.	DESCRIPTION
691117-1	Mandatory adapter for S.D. Lead and G-lead to DET monitor

#### O: DETONATION SENSING HARNESS

PART NO.	DESCRIPTION
593052-6	Shielded 6", Overall 300" 24 AWG 180°
593052-12	Shielded 12", Overall 300" 24 AWG 180°
593052-18	Shielded 18", Overall 300" 24 AWG 180°
593052-24	Shielded 24", Overall 300" 24 AWG 180°
593052-36	Shielded 36", Overall 300" 24 AWG 180°
593052-48	Shielded 48", Overall 300" 24 AWG 180°
593052-72	Shielded 72", Overall 300" 24 AWG 180°
593052-96	Shielded 96", Overall 300" 24 AWG 180°
593052-120	Shielded 120", Overall 300" 24 AWG 180°
593052-180	Shielded 180", Overall 300" 24 AWG 180°
593057-6	Shielded 6" Overall 300" 24 AWG 90°
593057-12	Shielded 12" Overall 300" 24 AWG 90°
593057-18	Shielded 18" Overall 300" 24 AWG 90°
593057-24	Shielded 24" Overall 300" 24 AWG 90°
593057-36	Shielded 36" Overall 300" 24 AWG 90°
593057-48	Shielded 48" Overall 300" 24 AWG 90°
593057-72	Shielded 72" Overall 300" 24 AWG 90°
593057-96	Shielded 96" Overall 300" 24 AWG 90°
593057-120	Shielded 120" Overall 300" 24 AWG 90°
593057-150	Shielded 150" Overall 300" 24 AWG 90°
593057-180	Shielded 180" Overall 300" 24 AWG 90°
593069-12	Shielded 12" 90° / 180°
593069-18	Shielded 18" 90° / 180°
593069-24	Shielded 24" 90° / 180°
593069-30	Shielded 30" 90° / 180°
593069-36	Shielded 36" 90° / 180°
593069-48	Shielded 48" 90° / 180°

# CPU-95/CPU-95EVS DIGITAL IGNITION SYSTEM

PART NO.	DESCRIPTION
593069-60	Shielded 60" 90° / 180°
593069-72	Shielded 72" 90° / 180°
593069-84	Shielded 84" 90° / 180°
593069-96	Shielded 96" 90° / 180°

## CPU-95EVS LAYOUT FOR USE WITH EIS SYSTEM

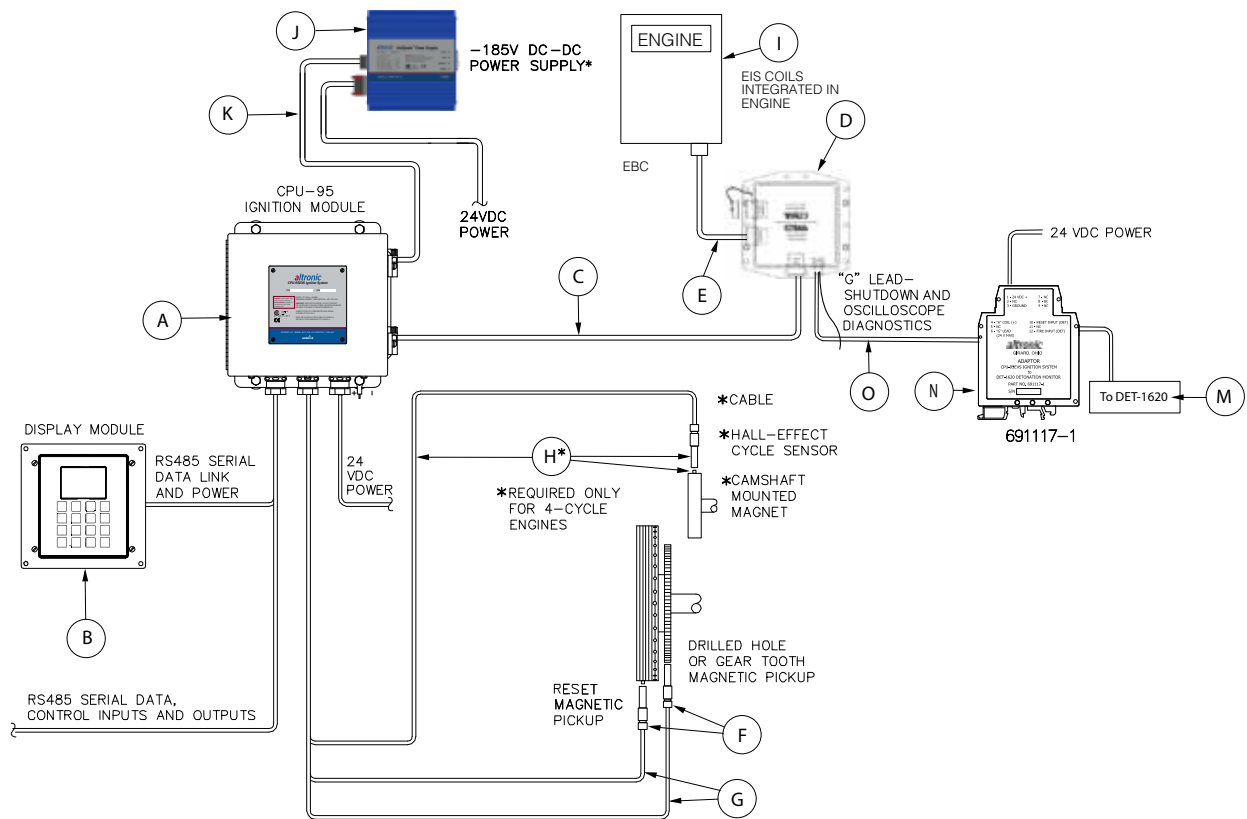

## CPU-95/CPU-95EVS DIGITAL IGNITION SYSTEM

ENGINE MODEL NO.		FIRING PATTERN	CPU-95 IGN. MODEL	OR	CPU-95 EVS IGN. MODEL	MEMORY CODE NO.	QTY. COILS	NOTES
<b>AJAX</b>								
2202, DPC-280		180°	791958-16	OR	791963-8	B2Axxx.FD	4	7, 8
2802, DPC-360		180°	791958-16	OR	791963-8	B2Axxx.FD	4	7, 8
2803, DPC-600		120°	791958-16	OR	791963-8	C2Axxx.FD	6	7, 8
2804, DPC-800		90°	791958-16	OR	791963-8	D2Axxx.FD	8	7, 8
<b>BERGEN (ROLLS ROYCE)</b>								
BVG	-12	55°-65°	791952-18	OR	791963-16	L4P180.FS539	12	1, 8
	-16	55°-35°	791952-18	OR	791963-16	P4F180.FS542	16	1, 8
	-20	55°-17°	791952-20		—	T4P180.FS543	20	1
KRGS	-8	90°	791952-18	OR	791963-8	H4A180.FS532	8	1, 8
	-9	80°	791952-18	OR	791963-16	I4A180.FS533	9	1, 8
KVGS	-12	50°-70°	791952-18	OR	791963-16	L4V180.FS534	12	1, 8
	-16	50°-40°	791952-18	OR	791963-16	P4V180.FS535	16	1, 8
	-18	10°-70°	791952-18		—	R4T180.FS536	18	1
<b>CATERPILLAR</b>								
300 Series	G379	60°-120°	791950-8 /-16	OR	791963-8	H4B183.FC	8	1, 4, 8
	G398	60°	791950-16	OR	791963-16	L4A183.FC	12	1, 4, 8
	G399	60°-30°	791950-16	OR	791963-16	P4T183.FC	16	1, 2, 4, 8
	G399	30°-60°	791950-16	OR	791963-16	P4P183.FC	16	1, 2, 4, 8
3300 Series	G3304	180°	791950-8 /-16	OR	791963-8	D4A156.FC	4	1, 8
	G3306	120°	791950-8 /-16	OR	791963-8	F4A156.FC	6	1, 8
3400 Series	G3406	120°	791950-8 /-16	OR	791963-8	F4A113.FC	6	1, 8
	G3408	90°	791950-8 /-16	OR	791963-8	H4A136.FC	8	1, 8
	G3412	55°-65°	791950-16	OR	791963-16	L4P136.FC	12	1, 8
3500 Series	G3508	90°	791950-8 /-16	OR	791963-8	H4A183.FC	8	1, 8
	si low emissions G3508	90°	791955-16	OR	791963-8	H4A183.G	8	6, 8
EIS low emissions	G3508	90°	—	OR	791963-8E	H4A183.G	8	9, 10, 11, 12
	G3512	60°	791950-16	OR	791963-16	L4A183.FC	12	1, 8
si low emissions	G3512	60°	791955-16	OR	791963-16	L4A183.G	12	6, 8
	EIS low emissions G3512	60°	—	OR	791963-16E	L4A183.G	12	9, 10, 11, 12
	G3516	60°-30°	791950-16	OR	791963-16	P4T183.FC	16	1, 2, 8
	G3516	30°-60°	791950-16	OR	791963-16	P4P183.FC	16	1, 2, 8
	si low emissions G3516	60°-30°	791955-16	OR	791963-16	P4T183.G	16	6, 8
EIS low emissions	G3516	60°-30°	—	OR	791963-16E	P4T183.G	16	9, 10, 11, 12
3600 Series	G3606	120°	791950-8 /-16	OR	791963-8	F4A255.FC	6	1, 8
	G3608	90°	791950-8 /-16	OR	791963-8	H4A255.FC	8	1, 8
	G3612	50°-70°	791950-16	OR	791963-16	L4V255.FC	12	1, 8
	G3616	50°-40°	791950-16	OR	791963-16	P4V255.FC	16	1, 8

## CPU-95/CPU-95EVS DIGITAL IGNITION SYSTEM

ENGINE MODEL NO.	FIRING PATTERN	CPU-95 IGN. MODEL	OR	CPU-95 EVS IGN. MODEL	MEMORY CODE NO.	QTY. COILS	NOTES	
<b>CLARK</b>								
BA, HBA, HLA	- 5	72°	791958-16	OR	791963-16	E2Axxx.FD	10	7, 8
	- 6	60°	791958-16	OR	791963-16	F2Axxx.FD	12	7, 8
	- 8	67.5°-22.5°	791958-16	OR	791963-16	H2Cxxx.FD	16	2, 7, 8
	- 8	22.5°-67.5°	791958-16	OR	791963-16	H2Hxxx.FD	16	2, 7, 8
	-10	36°	791958-16		—	J2Axxx.FD	20	7
MA,HMA,HMB,TMB	- 4	90°	791958-16	OR	791963-8	D2Axxx.FD	4 / 8	7, 8
	- 6	60°	791958-16	OR	791963-16	F2Axxx.FD	6 / 12	7, 8
	- 8	22.5°-67.5°	791958-16	OR	791963-16	H2Hxxx.FD	8 / 16	7, 8
	-10	36°	791958-16		—	J2Axxx.FD	10 / 20	7
RA, HRA	-32	120°	791958-16	OR	791963-8	C2Axxx.FD	6	7, 8
	- 4	90°	791958-16	OR	791963-8	D2Axxx.FD	8	7, 8
	- 5	72°	791958-16	OR	791963-16	E2Axxx.FD	10	7, 8
	- 6	60°	791958-16	OR	791963-16	F2Axxx.FD	12	7, 8
	- 8	45°	791958-16	OR	791963-16	H2Axxx.FD	16	7, 8
<b>COOPER BESSEMER</b>								
GMV (short stroke)- GMX series	- 4	63°-117°	791958-16	OR	791963-8	D2Fxxx.FD	4	7, 8
	- 6	63°-57°	791958-16	OR	791963-8	F2Fxxx.FD	6	7, 8
	- 8	63°-27°	791958-16	OR	791963-8	H2fxxx.FD	8	2, 7, 8
	- 8	27°-63°	791958-16	OR	791963-8	H2Fxxx.FD	8	2, 7, 8
	-10	63°-9°	791958-16	OR	791963-16	J2fxxx.FD	10	2, 7, 8
	-10	9°-63°	791958-16	OR	791963-16	J2Fxxx.FD	10	2, 7, 8
GMV, GMVA,	- 4	60°-120°	791958-16	OR	791963-8	D2Bxxx.FD	4 / 8	7, 8
GMVC, GMVE	- 6	60°	791958-16	OR	791963-16	F2Axxx.FD	6 / 12	7, 8
	- 8	60°-30°	791958-16	OR	791963-16	H2Txxx.FD	8 / 16	2, 7, 8
	- 8	30°-60°	791958-16	OR	791963-16	H2Bxxx.FD	8 / 16	2, 7, 8
	-10	60°-12°	791958-16		—	J2bxxx.FD	10 / 20	2, 7
	-10	12°-60°	791958-16		—	J2Bxxx.FD	10 / 20	2, 7
GMW, GMWA,	- 6	36°-84°	791958-16	OR	791963-16	F2Dxxx.FD	12	7, 8
GMWC, GMWE	- 8	36°-54°	791958-16	OR	791963-16	H2Dxxx.FD	16	7, 8
	-10	36°	791958-16		—	J2Axxx.FD	20	7
	-12	36°-24°	791958-16		—	L2dxxx.FD	24	2, 7
	-12	24°-36°	791958-16		—	L2Dxxx.FD	24	2, 7
JS, LS	- 6	120°	791958-16	OR	791963-16	F4Axxx.FC	12	7, 8
	- 6	4°-116°	791952-18	OR	791963-16	L4Sxxx.FC	12	8
	- 8	90°	791958-16	OR	791963-16	H4Axxx.FC	16	7, 8
	- 8	4°-86°	791952-18	OR	791963-16	P4Sxxx.FC	16	8

## CPU-95/CPU-95EVS DIGITAL IGNITION SYSTEM

ENGINE MODEL NO.	FIRING PATTERN	CPU-95 IGN. MODEL	OR	CPU-95 EVS IGN. MODEL	MEMORY CODE NO.	QTY. COILS	NOTES	
<b>GUASCOR</b>								
SFGLD	-180	120°	791950-8 /-16	OR	791963-8	F4A178.FC	6	1, 8
	-240	90°	791950-8 /-16	OR	791963-8	H4A178.FC	8	1, 8
	-360	60°	791950-16	OR	791963-16	L4A165.FC	12	1, 8
	-420	60°	791950-16	OR	791963-16	L4A165.FC	12	1, 8
	-480	30°-60°	791950-16	OR	791963-16	P4P165.FC	16	1, 8
	-560	30°-60°	791950-16	OR	791963-16	P4P165.FC	16	1, 8
<b>INGERSOLL RAND</b>								
KVG, KVGR	- 26	165°-75°	791958-16	OR	791963-8	F4Cxxx.FC	6	7, 8
	- 36	165°-75°	791958-16	OR	791963-8	F4Cxxx.FC	6	7, 8
	- 48	90-90-90-135-90-90-90-45	791958-16	OR	791963-8	H4Exxx.FC	8	7, 8
	- 48	90-135-45-135-90-45-135-45	791958-16	OR	791963-8	H4Kxxx.FC	8	7, 8
	- 62	165°-75°	791958-16	OR	791963-8	F4Cxxx.FC	6	7, 8
	- 82	45°-135°	791958-16	OR	791963-8	H4Hxxx.FC	8	7, 8
	- 83	90-90-90-135-90-90-90-45	791958-16	OR	791963-8	H4Exxx.FC	8	7, 8
	-103	117°-27°	791958-16	OR	791963-16	J4exxx.FC	10	2, 7, 8
	-103	27°-117°	791958-16	OR	791963-16	J4Exxx.FC	10	2, 7, 8
	-104	117°-27°	791958-16	OR	791963-16	J4exxx.FC	10	2, 7, 8
	-104	27°-117°	791958-16	OR	791963-16	J4Exxx.FC	10	2, 7, 8
	-123	45°-75°	791958-16	OR	791963-16	L4Hxxx.FC	12	7, 8
	-410	117°-27°	791958-16	OR	791963-16	J4exxx.FC	10	2, 7, 8
	-410	27°-117°	791958-16	OR	791963-16	J4Exxx.FC	10	2, 7, 8
	-410	45-120-75-45-75-45-75-120-45-75	791958-16	OR	791963-16	J4Gxxx.FC	10	7, 8
	-412	45°-75°	791958-16	OR	791963-16	L4Hxxx.FC	12	7, 8
-512	45°-75°	791958-16	OR	791963-16	L4Hxxx.FC	12	7, 8	
KVS, KVSR	- 36	165°-75°	791958-16	OR	791963-16	F4Cxxx.FC	12	7, 8
	- 48	90-135-45-135-90-45-135-45	791958-16	OR	791963-16	H4Kxxx.FC	16	7, 8
	-410	45-75-45-75-120-45-75-45-75-120	791958-16		—	J4Sxxx.FC	20	7
	-412	45°-75°	791958-16	OR	—	L4Hxxx.FC	24	7
	-512	45°-75°	791958-16	OR	—	L4Hxxx.FC	24	7
PKVG, PKVGR	- 6	165°-75°	791958-16	OR	791963-8	F4Cxxx.FC	6	7, 8
	- 8	90-90-90-135-90-90-90-45	791958-16	OR	791963-8	H4Exxx.FC	8	7, 8
	- 10	117°-27°	791958-16	OR	791963-16	J4exxx.FC	10	2, 7, 8
	- 10	27°-117°	791958-16	OR	791963-16	J4Exxx.FC	10	2, 7, 8
	- 12	45°-75°	791958-16	OR	791963-16	L4Hxxx.FC	12	7, 8

## CPU-95/CPU-95EVS DIGITAL IGNITION SYSTEM

ENGINE MODEL NO.	FIRING PATTERN	CPU-95 IGN. MODEL	OR	CPU-95 EVS IGN. MODEL	MEMORY CODE NO.	QTY. COILS	NOTES	
<b>INGERSOLL RAND</b> (continued)								
PKVS, PKVSR	- 6	165°-75°	791958-16	OR	791963-16	F4Cxxx.FC	12	7, 8
	- 8	90-135-45-135 -90-45-135-45	791958-16	OR	791963-16	H4Kxxx.FC	16	7, 8
	-10	45-75-45-75-120- 45-75-45-75-120	791958-16		—	J4Sxxx.FC	20	7
	-12	45°-75°	791958-16		—	L4Hxxx.FC	24	7
PSVG	- 6	185°-55°	791958-16	OR	791963-8	F4Pxxx.FC	6	
	- 8	90-90-90-65- 90-90-90-115	791958-16	OR	791963-8	H4Pxxx.FC	8	7, 8
	-10	137°-7°	791952-18	OR	791963-16	J4pxxx.FC	10	2, 8
	-10	7°-137°	791952-18	OR	791963-16	J4Pxxx.FC	10	2, 8
	-12	65°-55°	791958-16	OR	791963-16	L4pxxx.FC	12	2, 7, 8
	-12	55°-65°	791958-16	OR	791963-16	L4Pxxx.FC	12	2, 7, 8
PVG, XVG	- 4	180-240-180-120	791958-16	OR	791963-8	D4Gxxx.FC	4	3, 7, 8
	- 6	60-180-120- 60-120-180	791958-16	OR	791963-8	F4Exxx.FC	6	7, 8
	- 8	60°-120°	791958-16	OR	791963-8	H4Bxxx.FC	8	7, 8
SVG	- 6	180°-60°	791958-16	OR	791963-8	F4Bxxx.FC	6	7, 8
	- 8	90-90-90-60- 90-90-90-120	791958-16	OR	791963-8	H4Gxxx.FC	8	7, 8
	-10	132°-12°	791958-16	OR	791963-16	J4dxxx.FC	10	2, 7, 8
	-10	12°-132°	791958-16	OR	791963-16	J4Dxxx.FC	10	2, 7, 8
	-12	60°	791958-16	OR	791963-16	L4Axxx.FC	12	7, 8
<b>JENBACHER</b>								
300 SERIES	J312GS	50°-70°	791950-16	OR	791963-16	L4V164.FC	12	1, 8
	J316GS	20°-70°	791952-18	OR	791963-16	P4W164.FC	16	1, 8
	J320GS	2°-70°	791952-20		—	T4S164.FC	20	1
600 SERIES	J612GS	60°	791950-16	OR	791963-16	L4A269.FC	12	1, 8
	J616GS	30°-60°	791950-16	OR	791963-16	P4P269.FC	16	1, 8
	J620GS	12°-60°	791952-20	OR	—	T4B269.FC	20	1
<b>M.E.P.</b>								
M.E.P.	- 6	60°	791950-8 /-16	OR	791963-16	F2A318.FD	12	1, 8
	- 8	45°	791950-8 /-16	OR	791963-16	H2A318.FD	16	1, 8
	-10	36°	791950-16		—	J2A318.FD	20	1
	-12	30°	791950-16		—	L2A318.FD	24	1
<b>MITSUBISHI</b>								
KU30G	-12	50°-70°	791950-18	OR	791963-16	L4V184.FS006	12	1, 8
	-14	50°-52.86°	791950-18	OR	791963-16	N4V184.FS010	14	1, 8
	-16	50°-40°	791950-18	OR	791963-16	P4V184.FS011	16	1, 8
	-18	50°-30°	791950-18		—	R4V184.FS012	18	1

## CPU-95/CPU-95EVS DIGITAL IGNITION SYSTEM

ENGINE MODEL NO.	FIRING PATTERN	CPU-95 IGN. MODEL	OR	CPU-95 EVS IGN. MODEL	MEMORY CODE NO.	QTY. COILS	NOTES	
<b>RUSTON</b>								
RK270G	-12	75°-45°	791950-16	—	L4C292.FD	24	1	
	-16	45°	791950-16	—	P4A292.FD	32	1	
<b>SUPERIOR</b>								
G825 Series	-6	120°	791958-16	OR	791963-8	F4A230.FC	6	1, 7, 8
	-8	90°	791958-16	OR	791963-8	H4A230.FC	8	1, 7, 8
	-12	48°-72°	791958-16	OR	791963-16	L4D276.FC	12	1, 5, 7, 8
	-16	48°-42°	791958-16	OR	791963-16	P4G276.FC	16	1, 5, 7, 8
GT825 Series	-6	120°	791958-16	OR	791963-8	F4A230.FC	6	1, 7, 8
	-8	90°	791958-16	OR	791963-8	H4A230.FC	8	1, 7, 8
	-12	48°-72°	791958-16	OR	791963-16	L4D276.FC	12	1, 5, 7, 8
	-16	48°-42°	791958-16	OR	791963-16	P4G276.FC	16	1, 5, 7, 8
GTL	-6	120°	791958-16	OR	791963-8	F4A230.FC	6	1, 7, 8
	-8	90°	791958-16	OR	791963-8	H4A230.FC	8	1, 7, 8
	-12	48°-72°	791958-16	OR	791963-16	L4D276.FC	12	1, 5, 7, 8
	-16	48°-42°	791958-16	OR	791963-16	P4G276.FC	16	1, 5, 7, 8
GTLA, GTLB	-6	120°	791950-8 /-16	OR	791963-8	F4A230.FS501	6	1, 8
	-8	90°	791950-8 /-16	OR	791963-8	H4A230.FS502	8	1, 8
	-12	48°-72°	791950-16	OR	791963-16	L4D276.FS503	12	1, 8
	-16	48°-42°	791950-16	OR	791963-16	P4G276.FS504	16	1, 8
SGT	-12	48°-72°	791958-16	OR	791963-16	L4D276.FC	12	1, 5, 7, 8
	-16	48°-42°	791958-16	OR	791963-16	P4G276.FC	16	1, 5, 7, 8
SGTA, SGTB	-8	90°	791950-8 /-16	OR	791963-8	H4A230.FS505	8	1, 8
	-12	48°-72°	791950-16	OR	791963-16	L4D276.FS503	12	1, 8
	-16	48°-42°	791950-16	OR	791963-16	P4G276.FS504	16	1, 8
1700 Series	1706G	120°	791950-8 /-16	OR	791963-8	F4A182.FS511	6	1, 8
	1712G	60°	791950-16	OR	791963-16	L4A193.FS512	12	1, 8
	1712G	55°-65°	791950-16	OR	791963-16	L4P193.FS513	12	1, 8
	1716G	60°-30°	791950-16	OR	791963-16	P4T193.FS514	16	1, 8
2400 Series	2406G	120°	791950-8 /-16	OR	791963-8	F4A180.FS521	6	1, 8
	2408G	90°	791950-8 /-16	OR	791963-8	H4A180.FS522	8	1, 8
	2412G	60°	791950-16	OR	791963-16	L4A180.FS523	12	1, 8
	2416G	60°-30°	791950-16	OR	791963-16	P4T180.FS524	16	1, 8



## CPU-95/CPU-95EVS DIGITAL IGNITION SYSTEM

ENGINE MODEL		FIRING PATTERN	CPU-95 IGN. MODEL	OR	CPU-95 EVS IGN. MODEL	MEMORY CODE NO.	QTY. COILS	NOTES
<b>WAUKESHA</b>								
7.5" Bore	H2475G	60°-120°	791950-8/-16	OR	791963-8	H4B204.FC	8	1, 8
	H2476G	60°-120°	791950-8/-16	OR	791963-8	H4B204.FC	8	1, 8
	L3711G	60°	791950-16	OR	791963-16	L4A204.FC	12	1, 8
	L3712G	60°	791950-16	OR	791963-16	L4A204.FC	12	1, 8
VGF Series	F18	120°	791950-8/-16	OR	791963-8	F4A150.FC	6	1, 8
GL, GLD, GSID	H24	90°	791950-8/-16	OR	791963-8	H4A150.FC	8	1, 8
	L36	60°	791950-16	OR	791963-16	L4A165.FC	12	1, 8
	P48	60°-30°	791950-16	OR	791963-16	P4T165.FC	16	1, 8
VHP Series	F2895	120°	791950-8/-16	OR	791963-8	F4A208.FC	6	1, 8
G, GL, GSI	F3521	120°	791950-8/-16	OR	791963-8	F4A208.FC	6	1, 8
	L5108	60°	791950-16	OR	791963-16	L4A208.FC	12	1, 8
	L5790	60°	791950-16	OR	791963-16	L4A208.FC	12	1, 8
	L7042/7044*	60°	791950-16	OR	791963-16	L4A208.FC	12	1, 8
	P9390	60°-30°	791950-16	OR	791963-16	P4T208.FC	16	1, 2, 8
	P9390	30°-60°	791950-16	OR	791963-16	P4P208.FC	16	1, 2, 8

\* Note: 7044: ignition only, does not interface to OEM Engine Control System

## WORTHINGTON

LTC	- 3	120°	791958-16	OR	791963-8	C2Axxx.FD	6	7, 8
	- 4	90°	791958-16	OR	791963-8	D2Axxx.FD	8	7, 8
	- 5	72°	791958-16	OR	791963-16	E2Axxx.FD	10	7, 8
	- 6	60°	791958-16	OR	791963-16	F2Axxx.FD	12	7, 8
	- 8	45°	791958-16	OR	791963-16	H2Axxx.FD	16	7, 8
SLHC	- 4	180-90-180-270	791958-16	OR	791963-8	D4Sxxx.FC	8	3, 7, 8
	- 5	144°	791958-16	OR	791963-16	E4Axxx.FC	10	7, 8
	- 6	120°	791958-16	OR	791963-16	F4Axxx.FC	12	7, 8
	- 7	102.86°	791958-16	OR	791963-16	G4Axxx.FC	14	7, 8
	- 8	90°	791958-16	OR	791963-16	H4Axxx.FC	16	7, 8
	-10	72°	791958-16		—	J4Axxx.FC	20	7
UTC, SUTC	- 5	72°	791958-16	OR	791963-16	E2Axxx.FD	10	7, 8
	- 6	60°	791958-16	OR	791963-16	F2Axxx.FD	12	7, 8
	- 7	51.43°	791958-16	OR	791963-16	G2Axxx.FD	14	7, 8
	- 8	45°	791958-16	OR	791963-16	H2Axxx.FD	16	7, 8
	-10	36°	791958-16	OR	—	J2Axxx.FD	20	7

## CPU-95/CPU-95EVS DIGITAL IGNITION SYSTEM

---

### APPLICATION NOTES:

1. Memory listed is for latest standard engine ring gear. Verify tooth count prior to programming CPU-95 for the application. If a different number of teeth/holes are to be sensed, the memory code no. must be changed accordingly.
2. This application is listed with two memory codes:  
**New Installations:**  
Use the 1st code listed (H2C, H2f, H2T, J2b, J2f, J4d, J4e, J4p, L2d, L4p, P4T); with these codes, start with harness lead "A" to no. 1 cylinder.  
**Replacing CPU-90 System:**  
Use the 2nd code listed (H2H, H2F, H2B, J2B, J2F, J4D, J4E, J4P, L2D, L4P, P4P); with these codes, connect harness lead "A" to the SECOND cylinder in the firing order and continue in accordance with the engine firing order, ending with cylinder no. 1.
3. The maximum number of holes or teeth for this application is 240.
4. Mounting adaptor kit 790005 available; use with disc 790111-1 for cycle trigger on Caterpillar models G379, G398 and G399. Requires housing (Caterpillar P/N 2N7425) if engine has right angle service meter drive.
5. Alternate ring gear has 249 teeth; check number to verify correct memory code no.
6. This application replaces an Altronic III and Interface Box; the engine must have the Caterpillar SI Timing Control.  
The CPU-95 system consists of:  
Item A, Ignition Module 791955-16  
Item B, Display Module 791902-2  
Item C, Output Harness  
Items D, E and G are not required.
7. Ignition Module 791958 series provides an extended spark duration option which may be beneficial for the engine application listed. The 791950 series previously specified for this application may also be used. Use one of the Altronic red coil options (591010, 591010-S, 591012) with Ignition Module 791958-16.
8. Ignition module 791963 series provides a directed energy topology that has the ability to make high current long duration sparks. This unit provides another option which may be beneficial for the engine application listed.
9. This application replaces the EIS ignition system, and does not replace the ADEM system both systems however have under the valve cover coils.  
  
Only CPU-95EVS system can be used due to the extra power required and consists of:  
Item A Ignition Module 791963-16E  
Item B Display Module 791909-1  
Item C, Output Harness to Junction Module  
Item D, 1 to 1 Junction Module  
Item E, Junction box to Engine Block Connector  
Items H,F,G Pickups and harnesses  
Item J, Power Supply Module  
Item K, Ignition to Power Supply Harness  
Item G is not required
10. Using output harness Item C and Junction Box Item D is required for verifying timing during commissioning due to a fully connectorized system.
11. Junction Box to Engine block connector harness Item E is designed specifically for the cylinder count as it decodes.
12. When using the CPU-95EVS with detonation monitoring, the use of adapter 691117-1 is mandatory in conjunction with DET-1620. DET-1600 can not be used. Reference Bulletin 517 for detailed wiring.