

Catalyst Monitor and Data Logger

Health Monitoring of NSCR or Oxidation Catalysts for Stationary Gas Engines

- Parameter monitoring for RICE MACT
- Monitors key catalyst operating parameters
- Alarm or shut down on temperature or pressure
- Data logging on board for periodic or continuous download or retrieval
- Automatic adjustment to AFR controllers
- Operator configurable
- Variety of I/O supported
- Non-resettable real time clock

There is a need to monitor various inputs and outputs to NSCR and oxidation catalysts to provide assurance that these devices are working properly. The Catalyst Monitor provides this function and is available in two versions:

1. FOR DATA LOGGING ONLY

This version monitors various inputs as configured by a user over an extended period of time.

2. FOR DATA LOGGING AND AUTOMATIC ADJUSTMENT OF THE CCC AFR SET POINT

The "Intelligent" version communicates via CAN-Bus with the Air/Fuel Ratio controller, making corrections to the setpoint to maintain low emissions levels and extend the useful life of the catalyst by using a special post catalyst NOX sensor.

Gas engines subject to RICE MACT are required to monitor catalyst temperatures continuously. Catalysts require heat to react with targeted emissions. The Cat Monitor will monitor both pre- and post-catalyst temperature and notify the user if either a minimum or maximum temperature is exceeded.

The Cat Monitor is available as a Data Logger only or as a real-time automatic trim to an AFR system.



Applications

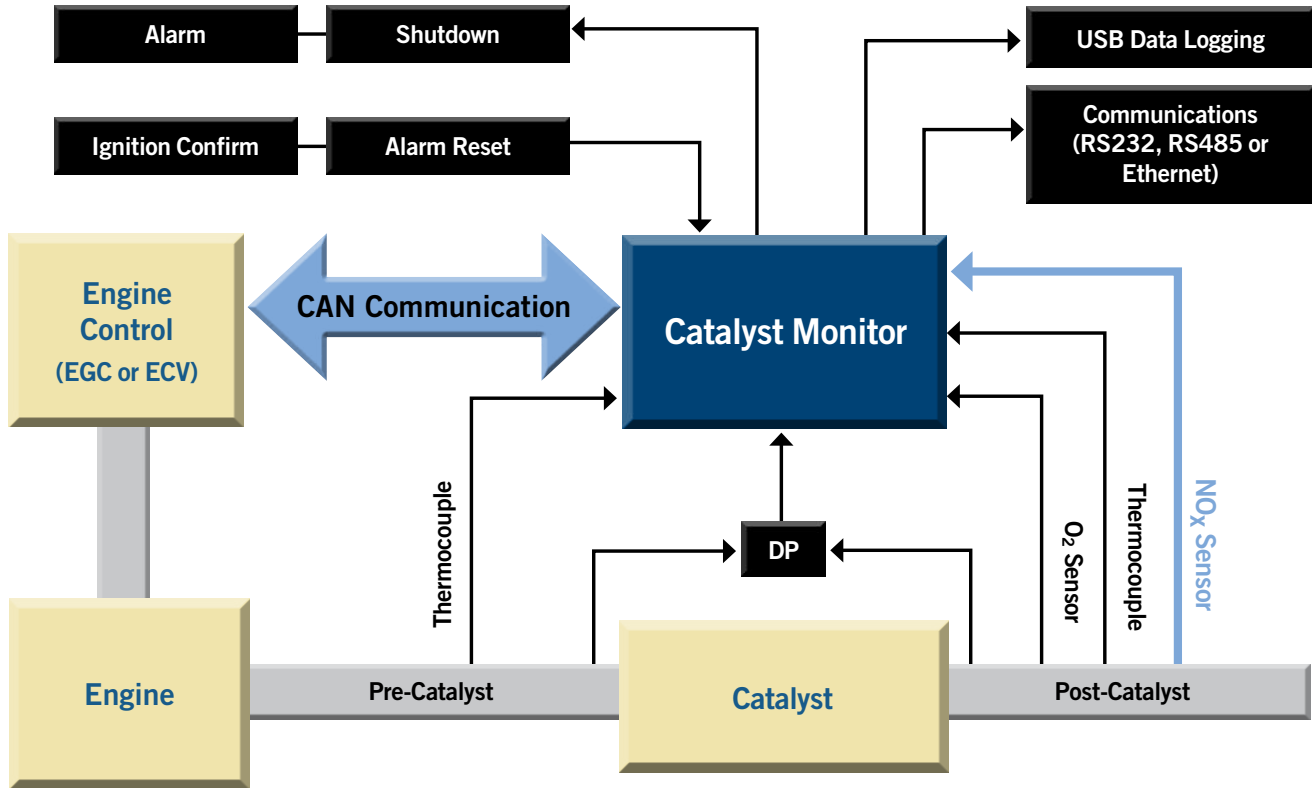

CATALYST MONITOR – SYSTEM LEVEL

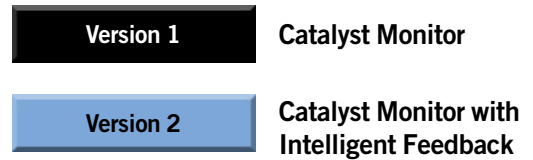

Increased differential pressure across the catalyst indicates masking/fouling of the catalyst elements. A substantial decrease in this differential pressure can indicate severe damage. The Cat Monitor logs the differential pressure, notifies the user of any unacceptable conditions, and ensures that the engine remains in compliance continuously.

Specifications

Power Requirement.....9-32Vdc
 Operating Temperature -40 to +85°C (-40 to +185°F)

INPUTS

Wide Band O2 Sensor.....2
 NOX Sensors2
 Thermocouple Inputs2
 Differential Pressure Input.....1
 4-20mA Input (possibly for Flow Measurement)1
 CAN-Bus Inputs (if NOX Sensors are not used)2

OUTPUTS

CAN-Bus Communications.....1
 Mod-Bus RS-232/485 for possible SCADA Interface or PC1
 Digital Discrete Outputs (Shut Down and/or Alarm)2
 USB Interface.....1
 LED Status Indication Lamp1
 Ethernet Communications1

Hazardous Environment

Designed to be Class 1, Div 2 Compliant
 IP 66 Compliant

ALTRONIC

A Member of the HOERBIGER Group

712 Trumbull Avenue / Girard, Ohio 44420
 (330) 545-9768 / Fax: (330) 545-9005
 www.altronic-llc.com Email: sales@altronic-llc.com

FORM CM 8-22 ©2022 Altronic, LLC