

Content

Content Page 1
 Attention Page 1
 Procedure Page 2

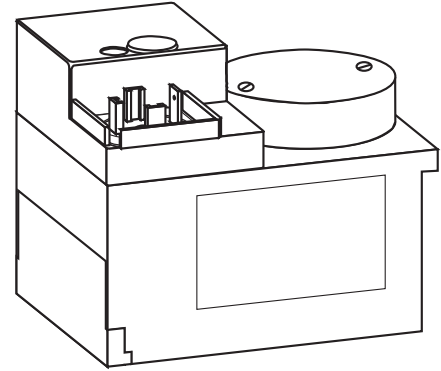

Attention



The installation and maintenance of this product must be done under the supervision of an experienced and trained specialist. Never perform work if gas pressure or power is applied, or in the presence of an open flame.

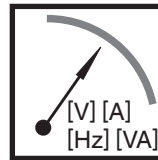

Check the ratings in the specifications to make sure that they are suitable for your application.



Please read the instruction before installing or operating. Keep the instruction in a safe place. You find the instruction also at www.dungs.com If these instructions are not heeded, the result may be personal injury or damage to property.



On completion of work on the safety valve, perform a leakage and function test.



Any adjustment and application-specific adjustment values must be made in accordance with the appliance-/boiler manufacturers instructions.

Explanation of symbols

- 1, 2, 3 ... = Action
- = Instruction

Procedure

1. Disconnect all power to prevent electrical shock and equipment damage.
2. Close the upstream manual shut off valve.
3. Remove DIN electrical connector.
4. Remove blue paint from the countersunk screw on the hydraulic brake unit (DMV-DLE series) or black adjustment knob (DMV-D series). (Fig. 1)
5. Remove the pan head screw on the hydraulic brake unit (DMV-DLE series) or black adjustment knob (DMV-D series). (Fig. 1)
6. Lift off the hydraulic brake unit or black adjustment knob.
7. Remove washer.
8. Remove solenoid by pulling directly up. Note solenoid # and voltage.
9. Verify the replacement coil has the same coil # and electrical rating. Install replacement coil.
10. Replace washer.
11. Check the o-rings (clean if necessary) on the hydraulic brake unit or black adjustment knob.
12. Remount the hydraulic brake unit or black adjustment knob. **During mounting, take care not to damage the o-rings on the shaft of the hydraulic brake on DMV-DLE models and the adjustment knob on DMV-D models.**
13. Install and secure screws to the hydraulic brake unit or black adjustment knob. Take care not to overtighten
14. With the gas pressure applied and valve #1 energized or with both valve energized, perform an external leakage test: Apply liquid leak detector around the gap between the hydraulic brake unit or black adjustment knob, the valve body and the solenoid.
15. If bubbles form, remove hydraulic brake unit or black adjustment knob. Check and clean o-rings. (If o-rings are damaged contact Karl Dungs, Inc. for a replacement hydraulic brake or black adjustment cap.) Inspect the bore in the cylinder shaft. Make sure it does not contain any debris or burrs. Make sure no dirt can come into the valve system. Remount the hydraulic brake unit or black adjustment knob. Perform leakage test again. If the valve still leaks contact Karl Dungs, Inc.
16. If no leak is detected, connect the DIN electrical connector.
17. Perform a complete function test: apply power to the valve, make sure both valves open and close properly.
18. If the valve does not operate properly, contact Karl Dungs, Inc. for technical help or replacement.

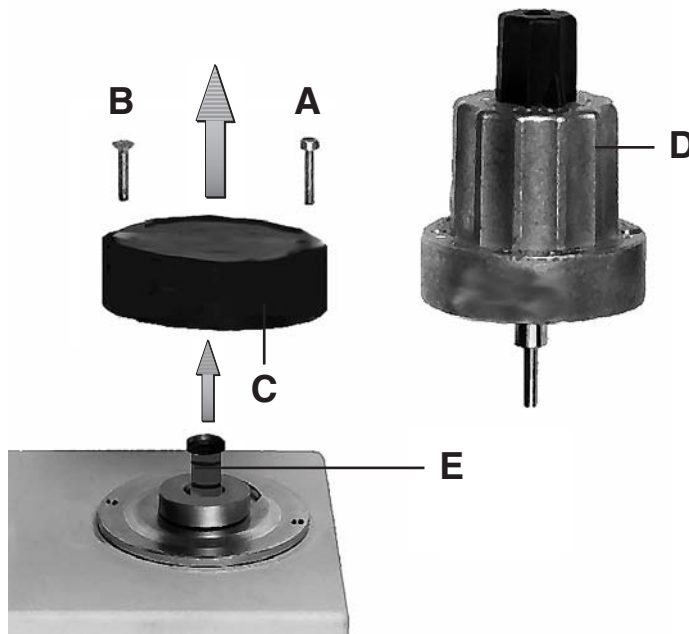

Karl Dungs Inc.
 3890 Pheasant Ridge Drive NE
 Suite 150
 Blaine, MN 55449, U.S.A.
 Phone 763 582-1700
 Fax 763 582-1799
 e-mail info@karldungsusa.com
 Internet <http://www.dungs.com/usa/>

Karl Dungs GmbH & Co. KG
 P.O. Box 12 29
 D-73602 Schorndorf, Germany
 Phone +49 (0)7181-804-0
 Fax +49 (0)7181-804-166
 e-mail info@dungs.com
 Internet <http://www.dungs.com>