

## GOV10/50 SERIES

### Self-contained Speed Governors and Fuel Control Valves with Optional Fuel Flow Meter for Engines up to 10,000 HP

- Integral electronics and state-of-the-art fuel valve
- Eliminates separate actuators and linkages
- Improved starting — sets gas pressure to pre-selected value and ramp rate
- Better speed stability — continuous dynamic gain adjustment for load and no load conditions
- Fail safe design — spring-loaded poppet valve closes on loss of power or gas pressure
- Total fuel flow and fuel flow/revolution displayed and outputted as analog and serial signals
- Serial communication of all critical data in modbus rtu
- High tolerance to dirt — flow-through design minimizes effects of contamination
- CSA-certified for Class I, Divisions 1 and 2, Group D hazardous areas

The GOV10/50 series is both a fuel valve and electronic governor integrated into a single unit. These governors fit a wide range of fuel injected engines including integral types such as Cooper Bessemer, Clark, Ingersoll Rand and Worthington, and separable types such as White Superior and MEP. The GOV10 model

is used on engines up to approximately 3,500 hp, whereas the GOV50 applies to engines from 3,500 to 10,000 hp.

The GOV series completely eliminate troublesome hydraulic governors, actuators, and linkages, and significantly improve starting performance and speed stability. The GOV series may also be ordered with a fuel flow measurement option utilizing a built-in orifice meter and built-in pressure, differential pressure, and temperature sensors. Utilizing fuel flow and fuel flow/revolution values, maximum engine horsepower and maximum engine torque limits can be applied for improved engine/compressor safety.

A sophisticated engine start-up and governing algorithm is resident in the GOV10/50 units allowing their use in conjunction with a PLC or simply as a stand-alone replacement governor. All configuration of control parameters, timers and setpoints is accomplished through the GOV Display Module.

The complete governor system consists of the GOV10 or 50 unit, a speed-sensing magnetic pickup, and the Display Module, a small computer-based terminal that serves as a display and configuration device. Internal construction and operation of the GOV series governors is explained on the inside pages.

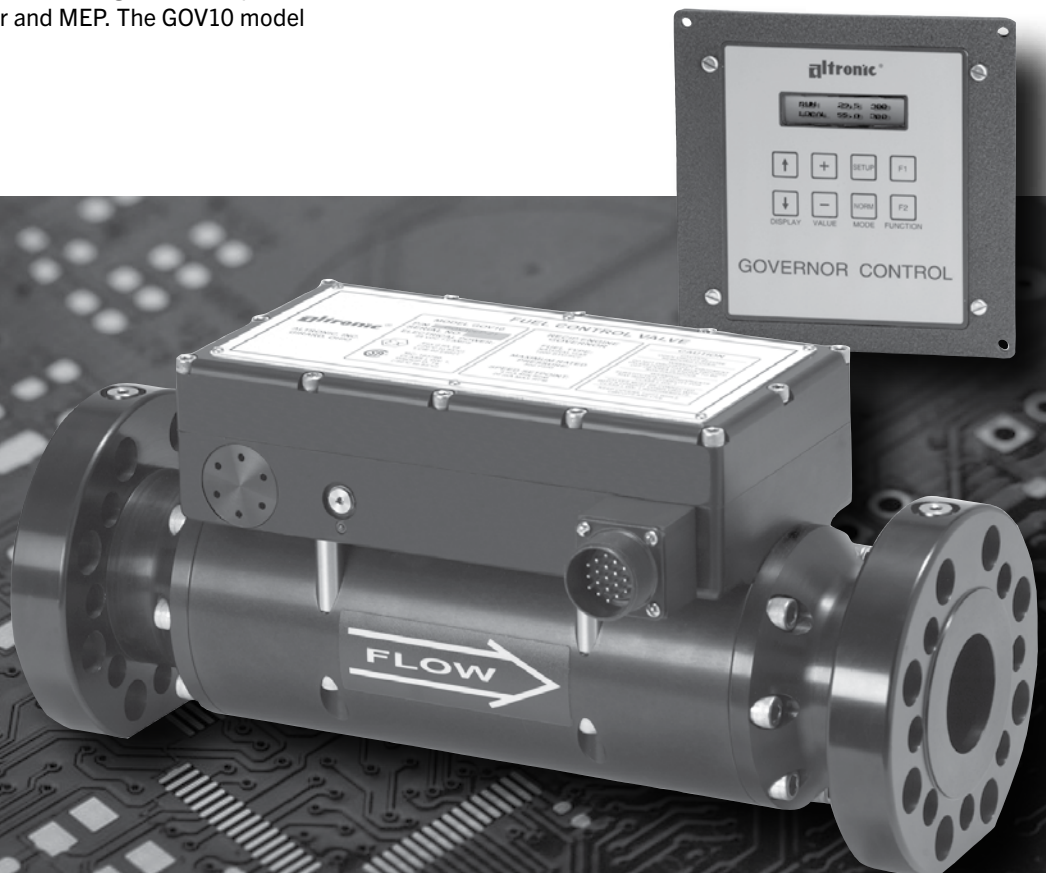

CERTIFIED  
CLASS I, DIVISIONS 1 and 2  
GROUP D

# GOV10/50 Series Self-contained Gas Engine Governor System Integration Diagram

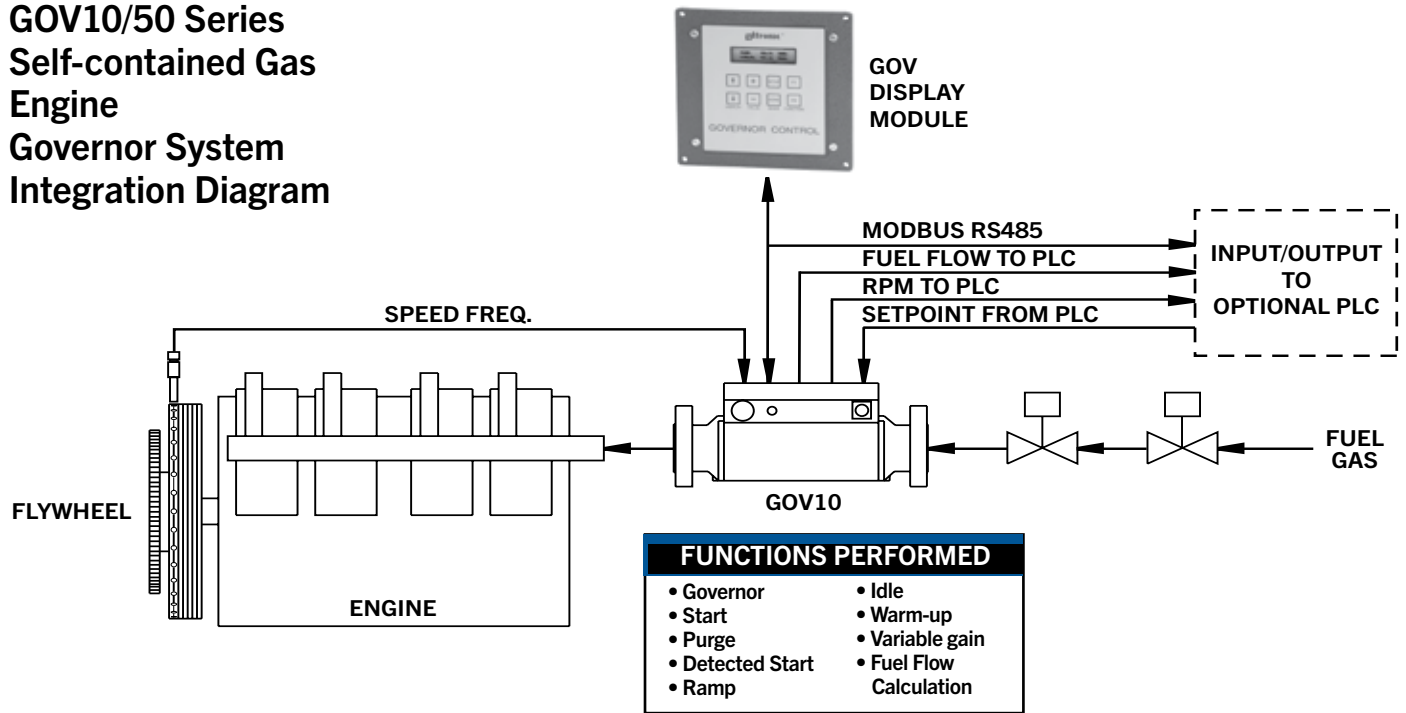

## GOV10/50 Theory of Operation

The GOV-series governors control engine fuel flow by varying an orifice with a spring-loaded poppet valve. Fuel gas pressure is used as the actuating force, therefore minimizing the need for electrical power. The governor consists of a tubular main body, a poppet assembly, and an electronics component housing.

The GOV controls gas flow by changing the position of the poppet valve very precisely in response to the speed control signal. The poppet valve is pre-loaded closed with 60 pounds of force, and the GOV remains closed when the engine is not running. While in this stopped mode, however, the GOV constantly monitors crankshaft speed. If the crankshaft speed exceeds its programmed set point, the GOV assumes that a start sequence is commencing and begins its start-up functions. If there is no fuel supply pressure sensed (the fuel block valve is closed), the GOV assumes that the engine is purging and remains closed, simultaneously activating the purge timer. When the purge timer has expired and the supply pressure exceeds the setpoint, the GOV begins controlling fuel manifold pressure for engine starting. The GOV uses a separate dedicated PID control loop to schedule and control fuel manifold pressure during starting, resulting in excellent engine starting performance.

After the engine fires off and engine speed exceeds another programmable set point, the GOV uses a programmable rate internal ramp and increases fuel flow to the engine until the minimum operating speed is achieved. At that time the GOV begins to increase fuel flow to the engine at the programmed ramp rate. When the engine speed set point is reached, the GOV operates as an engine speed governor, changing fuel flow as required to maintain the required set point. The governor gain dynamically changes based upon engine load. This feature helps keep the engine speed as stable as possible.

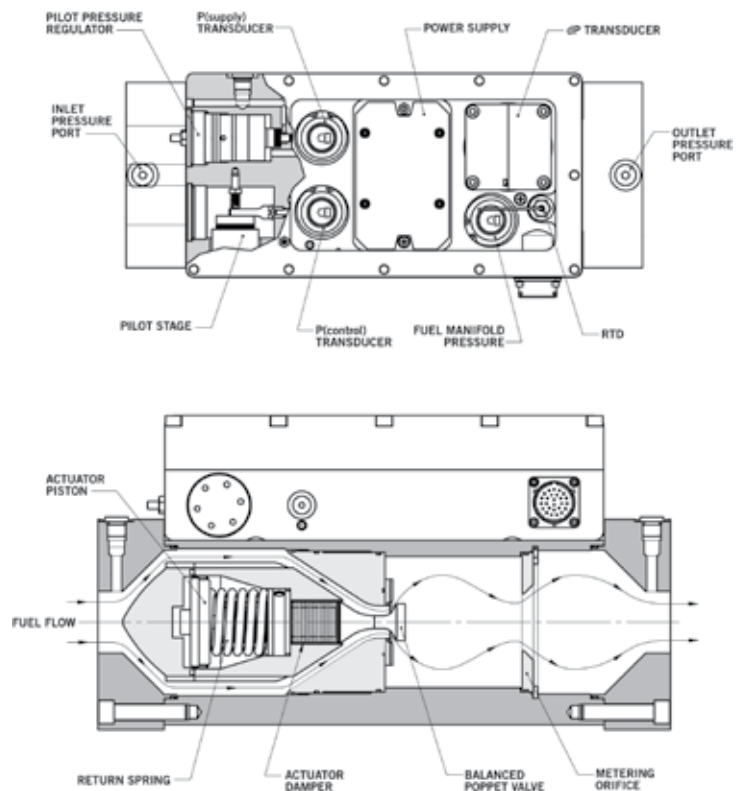

## GOV Display Module

- User-friendly display and interface device to the GOV series governor
- Displays RPM, fuel pressure and other critical information
- Allows control of speed setpoint and GOV tuneable setpoints

The GOV Display Module is a small, microprocessor-based display used for man-machine interface with the GOV governor. It communicates serially with the GOV unit and can be mounted in a remote location, such as in the engine control panel. The front panel consists of a 2X16 character LCD display and eight function keys. This backlit display is large enough to accommodate both an alphanumeric description of the value being displayed, and a numeric indication of that value. The GOV Display Module offers three operating modes: NORMAL, SET-UP, and PROGRAM. Adjustment of the speed setpoint (up or down) is accomplished through the Display Module as well.

In the NORMAL mode, a number of different parameters may be displayed (all in a read-only format). Examples are RPM, upstream supply gas pressure, downstream pressure, fuel gas temperature, etc.

The SET-UP mode gives the operator access to all essential GOV setup parameters which can be adjusted (up or down) utilizing the keys on the GOV Display Module. Set point RPM, purge time, and overspeed setpoint are examples of parameters adjustable while in this mode.

When the PROGRAM mode is accessed, a qualified individual is able to edit values critical to the operation of the governor. Examples are the governor gain values and the number of pulses per revolution seen by the magnetic pickup. These values are normally set during initial startup. Access to the PROGRAM mode is pass key protected for maximum application security.

## Fuel Flow Measurement Option

- Eliminates the need for separate unit fuel meters
- Displays engine fuel flow in SCFM (standard cubic feet per minute) and SCFR (standard cubic feet per revolution)
- Fuel flow and fuel flow per revolution can be output to a PLC for use in deriving horsepower and unit torque
- Measured using an internal orifice plate as well as pressure and temperature sensors

The GOV series can be ordered with an optional fuel flow measurement capability. By measuring the differential pressure across an orifice plate within the valve itself, the basic engine fuel flow and fuel flow per revolution is derived and displayed in the GOV Display Module. These parameters, along with engine speed, can also be ported to a supervisory control system via Modbus RTU or 4-20mA outputs for the dynamic computation of engine horsepower and torque.



## Application Photos



## Specifications

### INPUT SIGNALS

Magnetic Pickup .....	(1) ring gear teeth or drilled holes
Control Inputs (24Vdc to activate) .....	Local/Remote
	Clear warm-up timer
Control Inputs (4–20mA) .....	Scavenge air

### RPM CONTROL INPUTS

Manual .....	Display module keypad
Analog .....	4–20mA control signal
Digital .....	RS-485 serial data

**CONTROL OUTPUT** ..... Solid state N.O. switch (speed switch)

**ANALOG OUTPUTS (2) selectable**..... Output 1 (default Flow feedback)  
Output 2 (default RPM feedback)

**COMMUNICATIONS**..... RS-485 serial (dual)  
ModBus protocol (RTU)

**POWER REQUIREMENTS**..... 24 Vdc, 1Amp

**TEMPERATURE**..... –40° F. to +185° F.  
–40° C. to +85° C.

## To Order

### GOVERNOR WITH MS CONNECTOR

Integral Engines 350 to 3,500 HP:

4-Bolt SAE Flange .....	GOV10EP-10AC
4-Bolt Flange and Fuel Flow .....	GOV10EP-10AFC
8-Bolt ANSI Flange.....	GOV10EP-20AC
8-Bolt Flange and Fuel Flow .....	GOV10EP-20AFC

Integral Engines 3,500 to 15,000 HP

4-Bolt SAE Flange.....	GOV50EP-10AC
4-Bolt Flange and Fuel Flow .....	GOV50EP-10AFC

### DISPLAY

Display Module .....

### FUEL FILTER KIT

External Filter Kit .....

### OPTIONAL ITEMS

Fuel Flow Option, field installed.....	809001
Governor Repair Kit.....	820002
By-pass Line Kit .....	820003
Board Assembly Update Kit .....	881001-KT*
MS Connector Adapter, field installed .....	893003
Harness, 48" (MS connector option).....	293023-16
Harness, 84" (MS connector option).....	293026-16
Harness, 96" (MS connector option).....	293028-16
Harness, 144" (MS connector option).....	293027-16

\*These items are also used to update an older GOV10/50 using the TCA-100 display.

## Applications

■ Clark	■ Cooper Bessemer
■ Ingersoll Rand	■ MEP
■ Superior	■ Worthington

## Dimensions

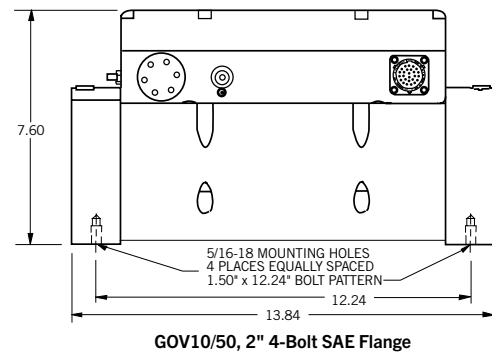
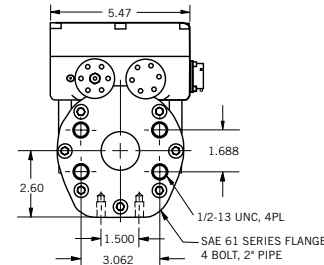
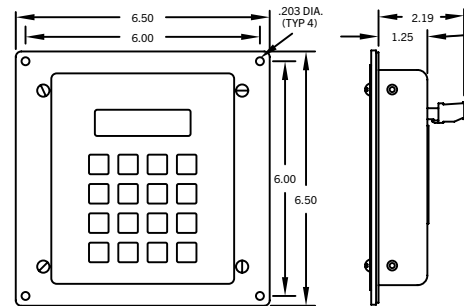

GOV10/50, 2" 4-Bolt SAE Flange

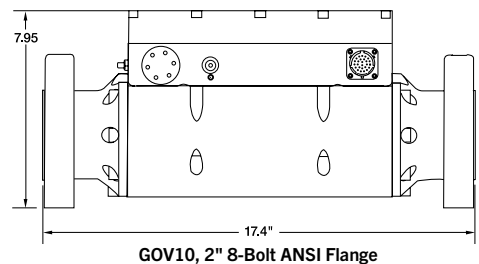
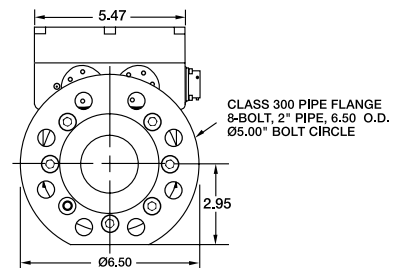

GOV10, 2" 8-Bolt ANSI Flange

# ALTRONIC

A Member of the HOERBIGER Group

712 Trumbull Avenue / Girard, Ohio 44420  
(330) 545-9768 / Fax: (330) 545-9005  
www.altronic-llc.com Email: sales@altronic-llc.com

FORM GOV 8-22 ©2022 Altronic, LLC