

# SERVICE BULLETIN

NUMBER 502B

11/10/10

## EPC-100 Board Replacements

Now that the EPC-100E has replaced the EPC-100 and EPC-100EF, replacement LOGIC boards (681064-1 and 681064-1R) will continue to be supplied with the original EPC-100 "Legacy" firmware. The "E" firmware chip for this logic board will be shipped loose with each replacement board so that if replacing a board in an "EF" or "E" unit, the correct chip is provided. These boards **DO NOT** include the CDROM or firmware for the associated display board to convert the unit to an "E" version.

Replacement DISPLAY boards (672124 and 672124R) are also configured as shipped for use in EPC-100 "Legacy" units. The "E" display firmware chip for this board will also be shipped loose with each replacement board so that if replacing a board in an "EF" or "E" unit, the correct chip is provided. These boards **DO NOT** include the CDROM or firmware for the associated logic board to convert the unit to an "E" version.

To update an EPC-100 to EPC-100E at the time of a board change-out:

- If replacing the Display Board, order upgrade kit 620011-1 also.
- If replacing the Logic Board, order display firmware chip 611038-1 and CDROM 609024-1 only.

The upgrade kit 620011-1 includes the following items needed to update or upgrade an existing EPC-100 to the EPC-100E current production standard.

- (1) 611037-1 Programmed Microprocessor, EPC-100E Logic Board Firmware
- (1) 611038-1 Programmed Microprocessor, EPC-100E Display Board Firmware
- (1) 602532-2 Label Logic, EPC-100E
- (1) 610243 Connector Plug 20 pin
- (1) 609024-1 CDROM, EPC-100E Terminal program

Production part numbers were shipped as follows, starting with the most recent:

PRODUCT	TYPE	LOGIC FIRMWARE	DISPLAY FIRMWARE	LABEL
EPC-100E	Single Board	611037-1	611038-1*	"E"
EPC-100EF	Single Board	611013-1	611012-1*	"EF"
EPC-100	Single Board	601974	601538 + 601651**	"Legacy"
EPC-100	Multi Board	601538 + 601652	601538 + 601651**	"Legacy"

\* The 601651 EPROM may, or may not, be in place in the EPC-100 "EF" units. It is not required in the "E" or "EF", and these models will work properly with or without it.

\* Use of the "E" 611037-1 Logic Firmware with the "EF" 611012-1 Display Firmware is compatible and will operate as an "E". If using the upgrade kit, it is advisable to replace the "EF" 611012-1 Display Firmware with the "E" 611038-1 Display Firmware. This "EF" Display Firmware (611012-1) is obsolete and is replaced by the "E" Display Firmware.

\*\* The 601651 EPROM must be in place in all units operating "Legacy" firmware.

*The 681064-1E board is also available with the 611037-1 logic firmware already installed. This board DOES NOT come with the 601974 "legacy" firmware shipped loose.*

## SERVICE BULLETIN

Also, the “E” firmware changes the function of the “Connect for Single Regulator” (same on the Legacy and “EF”) terminals to a function known as “Remote F1 Start”. The selection of single or dual bank control is done through the display on the “E” version. This new feature in the “E” allows for a remote F1 Start to be performed via relay logic by momentarily grounding this terminal.

Using a jumper on the newer board will cause an AUTO ENGINE OFF error. This new connection allows a REMOTE F1 START to be executed by a momentary connection from this input to the COMMON GND.

### THE EPC-100E MUST USE A MENU SELECTION TO SELECT SINGLE OR DUAL BANK OPERATION.

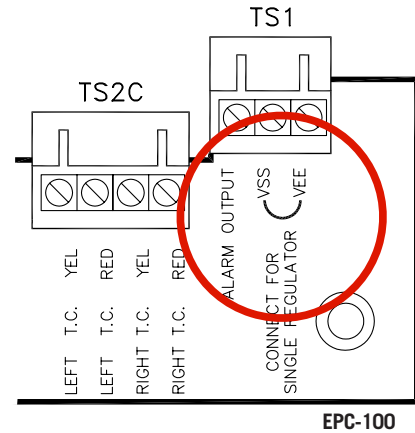

### Installation Guide: EPC-100E Enhanced Feature Firmware Kit

#### REQUIRED ITEMS

- EPC-100E Enhanced Feature Firmware Kit
- IC Extraction Tool
- Personal Computer with RS232 or RS485 serial port
- RS232 cable or RS485 converter with cables
- Small clip lead

#### REMOVE POWER FROM THE EPC-100

This can be done at the power source, or by disconnecting the 4-position terminal block, T2SA that provides power to the EPC-100.

#### INSTALL THE DISPLAY BOARD FIRMWARE

On the display board of the EPC-100 locate the 40-pin IC in the blue or black socket. Using an IC extraction tool, remove and save the 40-pin IC and replace it with new part labeled 611038-1, EPC100E DSP (orientation notch of this part should be installed UP).

#### INSTALL THE LOGIC/TERMINAL BOARD FIRMWARE

On the logic/terminal board of the EPC-100 locate the 40-pin IC in the blue or black socket. Using an IC extraction tool, remove and retain the 40-pin IC and replace it with new part labeled 611037-1, EPC100E LOG (orientation notch of this part should be installed DOWN).

#### INSTALL THE 20-POSITION EXPANSION TERMINAL BLOCK

The 20-position plug-in terminal block provided in the kit provides access to the expanded I/O functions of the logic board. These include two thermocouples, two O2 sensor inputs, four generic 0-5v analog inputs and four digital outputs.

#### INSTALL THE LOGIC BOARD LABEL

A replacement adhesive label is provided which includes a legend of the expanded connections of the new connector. Peel off the old label and apply the new one if required.

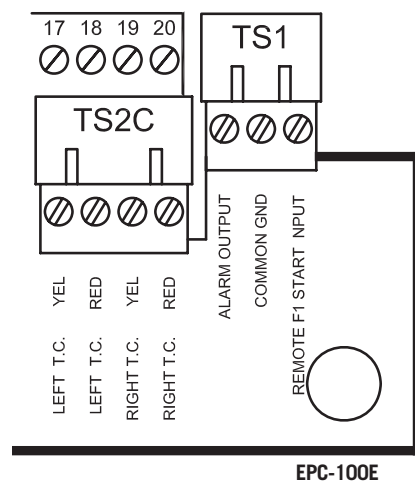

**ATTENTION: After installing firmware chips, the default settings must be loaded by connecting two pins of the logic microprocessor. This must be done any time the chip versions are changed.**

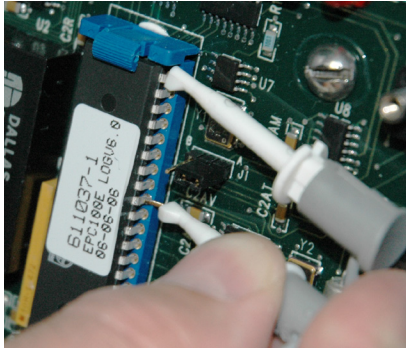

**NOTE:** Configuration of advanced features can only be performed using a PC and the terminal program. Install the program from the CD-ROM included in the kit.

**PRE-LOAD DEFAULTS ON FIRST POWER-UP OF EPC-100E**

Locate the EPC-100E LOG 40-pin IC on the logic board. Connect a clip lead between PIN 20 and PIN 12 (PAGE 4) of the IC to force a reload of defaults on power-up. With the pins connected, apply power and verify operation of the display. The stepper motor position will read 999 when the initialization process has been completed. Remove power and disconnect the clip lead. At this point, the EPC-100E has been loaded with default values and will operate like a standard EPC-100 with the addition of catalyst protection features which can be configured from the keypad using setup screens. Other enhanced features can only be activated and configured using the terminal program.

**INSTALL THE TERMINAL PROGRAM ON THE PC TO BE USED FOR SETUP**

It is possible to communicate using a standard RS232 connection or an RS485 connection which also requires an RS232 to RS485 converter (B&B Electronics Model 4WSD9R with switches set as follows (RS-485, EchoOFF, 2wire, 2wire).

**CONFIGURE THE EPC-100E FOR COMMUNICATION**

With the new firmware installed and initialized, apply power and verify operation of the display. Enter the setup mode (F1,F3,F2,F4) then press F1 to locate the screens to select the communication parameters. Select the port and protocol (RS232 9600N81 is recommended), then select the MODBUS node ID (100 is recommended).

**CONNECT TO THE EPC-100E WITH THE TERMINAL PROGRAM**

Connect the cable from the PC to the EPC-100 (RS-232 DB9 recommended). Run the program (EPC-100E) and choose the appropriate MODBUS ID# and CONNECTION menu parameters and the program should begin to communicate. A description on the bottom right can be useful in troubleshooting communication errors.

**ENABLE DESIRED ENHANCED FEATURES**

From the MENU bar click the FEATURES menu and click any feature you would like to enable. A check mark will identify enabled features, and configuration TABS will be added to provide access to configuration values of various features.

**CONFIGURE DESIRED ENABLED ENHANCED FEATURES**

At this point, referencing the operating manual, EPC-100E OM 5-06, configure the EPC-100E operation to suit the application enhancements as required. This would be done in conjunction with the installation and wiring of additional I/O signals to be used with the new features. Various TABS provide access to the features which have been turned on by means of the FEATURES menu.

