

Operating Manual

SaveAir®, Electronic Engine Air Starter

Form SA OM 11-14



1.0 OVERVIEW

- 1.1 The Altronic SaveAir® starting system has been designed for application on large, natural gas fueled engines and integral compressors which use in-head air starting. The SaveAir system is field-programmable and provides start air valve control and cranking speed control as well as diagnostic features. This manual provides instruction and maintenance information for the SaveAir. It is recommended that the user read this manual in its entirety before commencing operations.
- 1.2 The SaveAir system is normally used with high pressure compressed air. High pressure compressed air, when contained within an enclosure such as a reciprocating engine or its tubing system, can explode in a violent manner.
- 1.3 The SaveAir starting system is a gas engine accessory designed to be used as the cranking control on reciprocating natural gas engines with in-head air starting. The SaveAir system controls both the timing and duration of the air pulse to the cylinders. The system controls air flow to the cylinders by opening and closing a pilot duty solenoid valve for each cylinder.
- 1.4 The SaveAir system consists of three main parts:
 - Electronic Air Start Distributor 291310-xx;
 - Output Module Assembly 291301-1 (10 outputs) or 291301-2 (20 outputs);
 - Display Module 291302-1.The system also requires the following harnesses:
 - One 293031-xx to connect the Electronic Air Start Distributor to the Output Module;
 - One 293034-48 to connect the Output Module to the Display Module;
 - One or two 29302x-16 harnesses to connect the Output Module to the solenoid valves.One solenoid valve is required for each output to be used by the system.
- 1.5 The SaveAir Display Module accomplishes all necessary input programming and data value read outs. The Display Module design allows remote mounting at the operating or shutdown panel board of the engine. RS-485 serial communications will allow up to 350 foot distance for the remote terminal location.
- 1.6 The SaveAir system is CSA certified for Class I, Division 2, Group D hazardous locations.

WARNING: DEVIATION FROM THESE INSTRUCTIONS MAY LEAD TO IMPROPER ENGINE OPERATION WHICH COULD CAUSE PERSONAL INJURY TO OPERATORS OR OTHER NEARBY PERSONNEL.

CAUTION: Do NOT attempt to operate, maintain, or repair the SaveAir unit until the contents of this document have been read and are thoroughly understood.

WARNING: It is necessary to always use extreme caution when working with any high pressure system.

2.0 MOUNTING ELECTRONIC AIR START DISTRIBUTOR

- 2.1 The 291310-xx Electronic Air Start Distributor mounts to any available camshaft speed drive on the engine. The distributor has a standard SAE ignition flange drive with either one tapped hole and one slot (-A) or two slots (-GV). If a camshaft speed SAE flange ignition drive is available, the unit can be directly mounted and no other hardware is required. If the camshaft speed drive is another configuration, an adaptor is required to provide the correct mounting interface for the Distributor—contact the Altronic distributor for details on adaptors.
- 2.2 Rotate the engine to TDC (Top Dead Center) on the *compression stroke* of the first cylinder in the firing order and remove the existing air distributor.
- 2.3 Place the SaveAir Electronic Air Start Distributor in position, aligning the drive coupling with the slot in the driving member, and attach it to the engine (or the adaptor) using 3/8"-16 bolts.

3.0 MOUNTING THE OUTPUT MODULE

- 3.1 The harness 293031-xx, which connects the Electronic Air Start Distributor to the 291301-x SaveAir Output Module, is available in lengths of 24, 48, and 72 inches. Select a location to mount the Output Module which is on, or near, the engine and within a suitable distance to connect to the Electronic Air Start Distributor using a harness of the appropriate length.
- 3.2 The Output Module should be located away from any extreme sources of heat. The operating ambient temperature range is -40°F to +185°F (-40°C to +85°C). Do not expose the Output Module to temperatures higher than those indicated here.

4.0 MOUNTING THE SAVEAIR DISPLAY MODULE

- 4.1 Mount the 291302-1 SaveAir Display Module inside a control panel or to a suitable flat surface, preferably off the engine, in such a manner as to minimize exposure to vibration. The Display Module should be mounted so that the display is at a convenient viewing height. Refer to FIGURE 3 for mounting dimensions. A NEMA 3R housing (720004-1) is also available as an alternative mounting option for the Display Module.
- 4.2 The Display Module should be mounted within 50 feet (15m) of the other SaveAir modules which are mounted on, or very near, the engine.
- 4.3 Operating temperature range of the Display Module is -40°F to 158°F (-40°C to 70°C). Humidity specification is 0 to 95%, non-condensing. Housed in an aluminum weatherproof enclosure, the SaveAir Display Module is splash resistant; however, the mounting site should provide as much protection from inclement weather as is practical. Avoid mounting the LCD display and keypad in direct sunlight.

5.0 MOUNTING THE SOLENOID VALVES

- 5.1 Mount the 690017-x solenoid valves at a convenient location for service near the OEM air start valves mounted on the cylinder head of the Cooper, or other engines which use a pneumatic, pilot-activated, in-head air check valve. Pilot activated in-head valves can be identified as having two pipes; one large and one small. The 690017-x solenoid valves should be mounted as close as possible to the air in-head valves (within 18"), and tubing should be ¼" (not 3/8") to minimize air volume in the tubing which can cause delayed activation. Supply air to the 690017-x valve can be larger than ¼", but after the solenoid valve it must be ¼".
- 5.2 On Clark engines, a special valve assembly 690018-1 is used to replace the mechanically-driven air start valve which is housed in an air chest assembly, typically mounted on the side of the engine. The 690018-1 assembly consists of a pilot duty solenoid valve connected to a pneumatically actuated, large area valve. The 690018-1 assembly is then connected to the cylinder head using high pressure flexible stainless steel tubing.
- 5.3 It is recommended that an in-line filter (part no. 615007) be installed in the air line supplying the control solenoid valves and in the outlet lines to each cylinder.

6.0 SYSTEM WIRING

- 6.1 GENERAL - The following instructions apply to the electrical requirements of the installation of the SaveAir system. All efforts should be made to conform to the applicable electrical code with regard to hazardous environment installations.
- 6.2 WIRING PRACTICE - Take care not to damage wiring insulation and take precautions against damage from vibration, abrasion or liquids in conduits. In addition, DO NOT run low voltage power, current loop, or communications wires in the same conduit as the ignition wiring or other high energy wiring such as AC power, etc. Keep wires at least 12 inches away from all high voltage wiring.

- 6.3 Electronic Air Start Distributor - Connect the 293031-xx harness to the SaveAir Electronic Air Start Distributor and route the flexible conduit assembly along the engine to the mounting position of the SaveAir Output Module, Altronic part number 291301-x. Both ends of harness are preterminated with 17 pin connectors.
- 6.4 SYSTEM POWER - The Output Module to Display Module harness 293034-xx will be used to accomplish all remaining electrical connections of the system of this section. Use wiring methods suitable for Class I, Division 2 locations for these connections from Output Module to the Display Module, power supply and digital/ analog IO signals. Power input to the system is accomplished through wires marked G(+) and J(-) of the 293034-xx harness. A slow-blow, 5 amp, in-line fuse is required for the +24V "G" connection. It is suitable to obtain power from the same 24 volt source that is used for the Altronic Ignition (e.g., CPU-2000).
- 6.5 DIGITAL INHIBIT INPUT - Connection of the digital input is accomplished through the wire marked "D" of harness 293034-xx connected to the Output Module. When the digital inhibit input is configured as "ON", the starter will be disabled unless this input is connected to the power ground by means of a manual switch or automation relay. This input would typically be controlled by the engine start panel or automation system.
- 6.6 DIGITAL PURGED OUTPUT - Connection of the isolated dry contact digital output is accomplished through the wires marked "E" and "F" of the harness 203034-xx connected to the Output Module. The output will close to indicate that the starting system has completed the configurable requirements of being purged.
- 6.7 ANALOG INPUT - Connection of the analog input is accomplished through the wire marked "C" of harness 203034-xx connected to the Output Module. Configured as a current loop having a 200 ohm receiving resistance, this input may be used for applications which would require an air start pressure sensor to inhibit or trigger a start attempt.
- 6.8 DISPLAY MODULE - The Output to Display harness 293034-xx is pre-wired with 50 feet of four-conductor shielded cable (P/N 503194-500) which provides power and RS-485 signals to the Display Module. This shielded cable should be routed in conduit to the display location and connected to the terminal strip of the Display Module per drawing 209304. Power is provided on pin "H" (red wire +24), pin "K" (black wire com). RS-485 connections are provided on pin "B" (white wire +) and pin "A" (green wire -).

IMPORTANT: Power for the Display Module must come from the SaveAir Output Module.

7.0 WIRING THE SOLENOID VALVES

- 7.1 Route the primary harness(es) 29302x-16 from the Output Module to a junction box. Use wiring methods suitable for Class I, Division 2 locations (for example flexible or rigid conduit) from the junction box to the solenoid valves. The wire used should be 16 AWG such as Altronic 503188. The valves are wired to operate in sequence just like the ignition system. The SaveAir Output Module always outputs in the same sequence.
- 7.2 Determine the proper wiring of the solenoids by writing in the engine firing order.

For the 291301-1 (10-output) module:

A B C D E F G H J K

(Write In the Engine Firing Order)

For the 291301-2 (20-output) module (A1 is connector 1, A pin; etc.):

A1-A2 B1-B2 C1-C2 D1-D2 E1-E2 F1-F2 G1-G2 H1-H2 J1-J2 K1-K2

Engine Order

7.3 Connect the harness leads in the junction box in accordance with the engine firing order as determined above. The leads from the junction box corresponding to the system outputs connect to the solenoid coil (+) lead. The (-) lead of each solenoid connects to the common "P" lead and to the engine ground in the junction box.

8.0 UNDERSTANDING THE HOME SCREEN

8.1 The home screen is designed to provide indication of the current status as well as critical operational characteristics. The template for the home screen includes a text description of the current SaveAir state. The template also includes numerical values for current engine position (POS), Engine RPM and supply pressure if the sensor is enabled. If starting is being inhibited the source of the inhibit is shown on line 2 as a "WAIT=" statement.

```
STATUS POS RPM
ON DURATIONo PSI
```

```
STATUS POS RPM
WAIT=CAUSE
```

8.2 The example of the home screen below depicts an engine rolling with the crankshaft position of 300 degrees and the start system turning the engine 20 RPM by actuating the starting valves for a duration of 80 degrees. The second screen depicts the addition of the Air Starter Pressure, 165psi, when a pressure sensor is connected and enabled.

```
ROLLING 300o 20
ON 80o
```

```
ROLLING 300o 20
ON 80o 165
```

Definitions of the status words and conditions are provide below:

- READY Engine is Stopped and conditions are ready to start.
- NotRDY Engine is Stopped but a condition violates ready requirements.
- TRYING Starter is actuating outputs, but engine is not yet turning.
- ROLLING Engine Rotation is detected but speed is too slow to begin purging.
- PURGING Engine is rotating with "RUN" output off to purge cylinders of residual fuel.
- STARTING Engine is now purged, digital output is on, waiting for ignition/fuel.
- FIRING Valve "ON" duration at 0 deg, RPM programmed in table is reached.
- RUNNING Firing state has persisted for RunCycles setting, starter is locked out.

8.3 When the engine is not running and the air starter is not active, the home screen will display either READY or NotRDY. The example home screens below depict the two possible stopped engine READY conditions. The lower lines indicate that the Digital Control Input is now open, or the air supply pressure is low, inhibiting the system from attempting a start.

```
READY 220o 0
WAIT=DIGopen
```

```
READY 220o 0
WAIT=AirLow 0
```

8.4 The NotRDY home screen example below depicts the stopped engine NOT READY condition that indicates that a start attempt will not begin until this unexpected condition is corrected.

```
NotRDY 220°  0
WAIT=RETRY
```

Definitions of the reasons for “WAIT” with the status reading “NotRDY” are listed below.

- RETRY Engine was running, starter waiting for new start command.
- Backward Engine rolled backwards.
- FluxLO Internal SaveAir problem, requires service.
- FluxHI Internal SaveAir problem, requires service.
- FluxDELT Internal SaveAir problem, requires service.
- TblErr A Firing pattern table angles out of order.
- TblErr I INITIATE table RPM values out of order.
- TblErr D DURATION table RPM values out of order.
- AirErrSS Air thresholds for stop, start or reset are out of order.

8.5 The Trying screen example below will be presented when a start is initiated and the engine has not yet begun to rotate. At this point, solenoids would be energized, trying to rotate the engine.

```
TRYING 220°  0
ON 110°  RPM
```

8.6 The ROLLING screen example below will be presented when rotation below the PURGE RPM setpoint is detected. The engine is turning but the speed is not sufficient to begin the purge cycle. If the speed drops back to zero, the state will return to TRYING.

```
ROLLING 220° 15
ON 110°  RPM
```

8.7 The PURGING cycle is started when the RPM is above the PURGE RPM setpoint. The purge counter counts engine cycles until the purge count is reached. When the PURGE count is completed, the digital output will turn ON to signal that the engine is ready for fueling. If the speed drops below the PURGE RPM setpoint, the purge counter will restart from zero.

```
PURGING 40
ON 90°  RPM
```

8.8 The STARTING state display indicates that the PURGING cycle is complete and the spark/fuel request output has been activated.

```
STARTING 60
ON 80°  RPM
```

8.9 The FIRING state display indicates that the engine has obtained Light-Off. This is defined to be the lowest RPM where the DURATION table value you have entered is equal to zero.

```
FIRING 90
ON 0°  RPM
```

8.10 The RUNNING state display indicates that the engine is running and the transition from starting has been made. The Transition from FIRING to RUNNING is made when the starting valve duration has been at zero degrees for the number of RUN CYCLES programmed by the user. The starting cycle is now complete.

```

RUNNING      300
              RPM
  
```

9.0 USING THE NORM KEY

9.1 From the READY or NotRDY screens, the history of the previous failed or aborted start attempt can be viewed by pressing the **NORM** key. The most common cause of a failed start attempt will have nothing to do with the starting system. As shown below, this start was aborted by opening the digital input. This would most likely be done by the operator or control panel to terminate a start attempt. As shown, the first press of the NORM key displays the reason for the abort, and a second press displays the status when the abort occurred. Pressing **NORM** a third time returns the home and WAIT cause.

```

READY  220°  0
WAIT=DIGOpen
  
```

Press NORM

```

READY  220°  0
ABORT=DIGOpen
  
```

Press NORM

```

READY  220°  0
ABORT@Firing
  
```

9.2 In the second example below, the system was configured with a pressure sensor to control the start sequence. While the engine was being purged, the air supply pressure decreased below the Air Stop setting, and the start was aborted due to low air supply pressure. The system will return to READY only if the digital input is opened or the pressure is decreased from 95psi to below the Air Reset threshold. Either of these actions would create a new WAIT cause and permit the system to be READY again.

```

NotRDY  220°  0
WAIT=RETRY  95
  
```

Press NORM

```

NotRDY  220°  0
ABORT=AirLow
  
```

Press NORM

```

NotRDY  220°  0
ABORT@PURGING
  
```

10.0 CONFIGURATION SCREENS FOR THE SAVEAIR VARIABLES

- 10.1 The USER adjustable values are entered from the CONFIGURATION screens. These values must be programmed prior to trying to start the engine. These values are rarely adjusted in normal use and should be accessed only by qualified personnel. The CONFIGURATION values are divided into sub-menu groups by function. The group name appears on the top line of the display. The groups are: INITIATE TBL, DURATION TBL, TDC PATTERN, ENGINE Config, and SENSOR Config. When in the CONFIGURATION mode, the SETUP key can be used to move between sub-menu groups, the arrow keys to move between screens within a group, and the plus/minus keys to adjust the setting.

Beginning at the HOME screen



NOTE: Adjustable parameters are always pointed to by the → character.

- 10.2 Program the INITIATE table, this is the “turn on” or INITIATE angle for each valve versus an RPM curve defined by up to ten table points. The INITIATE angles are shown in degrees ATDC of all of the cylinders. Typically the INITIATE angle for the first value at 0 RPM will be the same used for other RPM entries (default of 5 deg. ATDC), or the smallest number of degrees ATDC in the table.



Press the **NEXT** key to advance to the next value

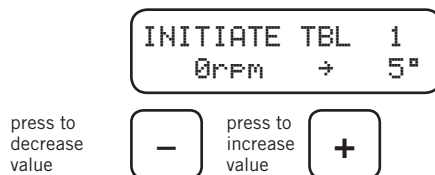

There are up to ten different RPM values which can be selected by the user. It is recommended that the default settings of this table be used for the first starting attempts until the user becomes familiar with the operation of the SaveAir system.

- 10.3 After completing the INITIATE table, press the **SETUP** key to move to the DURATION table. The DURATION table defines the desired “ON ANGLE” (pulse width) for the air start valves in terms of engine degrees versus the engine RPM. The first value is the number of engine degrees to leave the valves open when the engine is stopped and is typically the largest DURATION in degrees. The DURATION curve versus RPM is defined by the table of ten USER programmed points. It is also suggested that the Default values be used as an initial starting point for a new installation. By reducing the pulse width in degrees of DURATION as the engine RPM increases, the USER can govern the maximum RPM the engine will crank and maximize the length of time that the engine will crank on a given volume of air. Additionally, the consistency of the cranking RPM lends itself to much better control of the starting conditions such as air/fuel ratio and improves the reliability of starting in general.

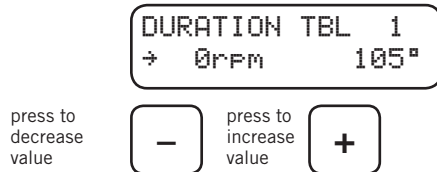

Press **NEXT** key to advance to the next value in the table. Remember that the RPM value which has a DURATION value of zero degrees will be the value used to determine that the engine is FIRING and (after the programmed number of engine cycles) that the engine condition is now RUNNING.

- 10.4 After completing the DURATION table, press the **SETUP** key to move to the engine crankshaft TDC PATTERN table. This table is programmed with the firing pattern of the engine in crankshaft degrees. Starting with the first cylinder in the pattern (A or A1) at zero degrees, enter the TDC position of the following cylinders equipped with air start valves as they appear in the firing order. Remember 2-stroke cycle engines complete a cycle every 360 degrees and 4 stroke cycle engines every 720 degrees of crankshaft rotation.

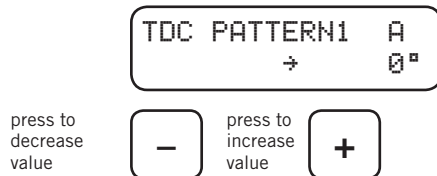

Press **NEXT** key to advance to the next value.

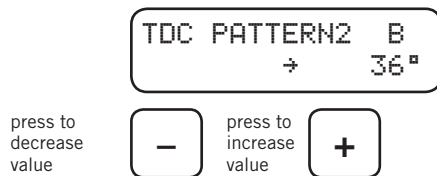

Complete the table for all cylinders with air start valves.

- 10.5 Press the **SETUP** key to advance to the ENGINE CONFIG table. The first screen is used to tell the SaveAir control how it is aligned to the engine position. The engine should be sitting at TDC on the **compression stroke** of the first cylinder in the firing order per section 2.3 of these instructions. Confirm this position. The readout will indicate the relative internal position of the Air Start Distributor, for example, 114 degrees.

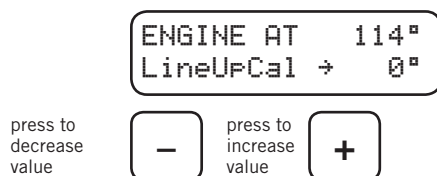

Using the +/- keys, adjust the LINE UP CAL value until the ENGINE AT value is 0°.

ENGINE AT 0°
 LineUpCal → 246°

press to
decrease
value

-

press to
increase
value

+

Then press the **NEXT** key to select the Output Module type. Use the +/- keys to select either 291301-1 with ten outputs or 291301-2 with twenty outputs.

ENGINE Config
 Module → 291301-1

press to
decrease
value

-

press to
increase
value

+

Press the **NEXT** key to advance to the next engine configuration screen. Select the number of starting valves being used.

ENGINE Config
 NumValves → 6

press to
decrease
value

-

press to
increase
value

+

Press the **NEXT** key to advance to the next engine configuration screen. Select the direction of engine rotation CW or CCW. This is the normal direction of rotation of the logic unit viewed from its drive end when the engine is running. Selected value is shown in CAPITAL letters.

ENGINE Rotation
 → cw/CCW 25.00

press to
select
CCW

-

press to
select
CW

+

Press the **NEXT** key to advance to the next engine configuration screen. Select the engine type 4 cycle or 2 cycle. Selected value is shown in CAPITAL letters.

ENGINE Config
 → 4cycle/2CYCLE

press to
select
2CYCLE

-

press to
select
4CYCLE

+

Press the **NEXT** key to advance to the next engine configuration screen. Select the INHIBIT starting by DIGITAL input ON or OFF. Selected value is shown.

ENGINE Config
 Inhibit DIG → ON

press to
select
OFF

-

press to
select
ON

+

Press the **NEXT** key to advance to the next engine configuration screen. Select the INHIBIT starting by Air Supply Pressure input ON or OFF. Selected value is shown. When ON, the home screen will include the measured pressure on the bottom right.

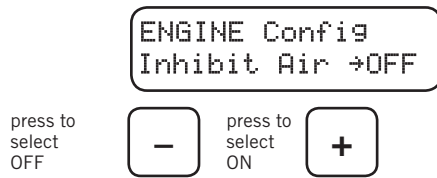

Press the **NEXT** key to advance to the next engine configuration screen. Select the PURGE RPM. This is the lowest RPM where purge cycles will be counted. Selected value is shown.

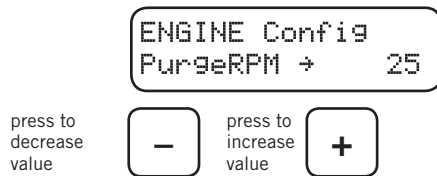

Press the **NEXT** key to advance to the next engine configuration screen. Select the number of PURGE cycles completed before the SaveAir output shows PURGE complete. Selected value is shown.

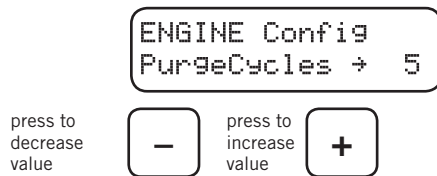

Press the **NEXT** key to advance to the next engine configuration screen. Select RunCycles, the number of engine cycles completed with the starting air valves having an ON duration of zero degrees before the engine is considered to be running under its own power and the starting system is locked out until a new starting sequence is attempted.

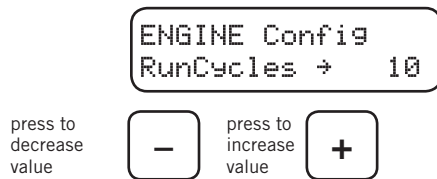

- 10.6 If the optional air pressure sensor is used, press the **SETUP** key to move to the SENSOR CONFIGURATION table. Set the Minimum Air Supply Pressure to begin a starting attempt. The current value being measured is shown on the top line of the display.

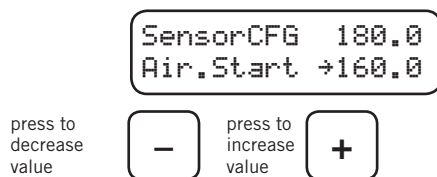

Press the **NEXT** key to move to the next value. Set the Minimum Air Supply Pressure to continue cranking after a start sequence has begun, before a start attempt is aborted.

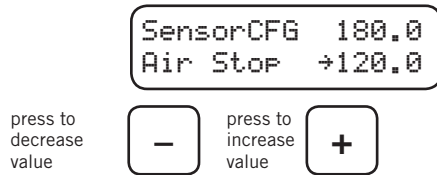

Press the **NEXT** key to move to the next value. Set the Air Supply Pressure to RESET the system for a new cranking attempt after a start sequence has ended. Pressure must drop below this value before a new start attempt is allowed.

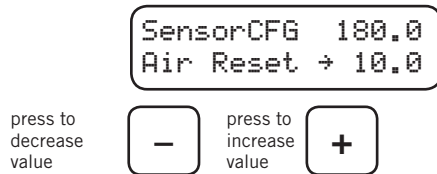

Press the **NEXT** key to move to the sensor SPAN calibration. The SaveAir unit is made to be used with an optional 4-20 milliamp transmitter to monitor air pressure. The input is designed for a single wire connection from the transmitter through an internal 200 ohm receiving resistor to ground. SPAN is the slope calibration point and should be equal to the full scale psi X 1.5625. Example shows the values for a 500 PSIG transducer.

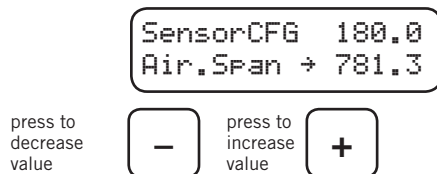

Press the **NEXT** key to move the sensor ZERO calibration. This should be the value corresponding to zero volts coming from the sensor. For the 500 PSIG sensor this is equal to $(-0.25 \times 500) = -125$

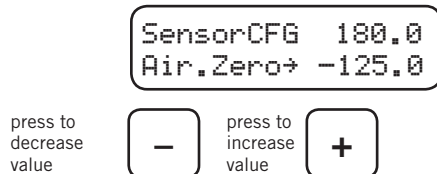

11.0 ADDITIONAL PARAMETER VIEW SCREENS

11.1 Additional parameters of interest can be selected for view by pressing the **PREV** or **NEXT** key to rotate through the various screens.

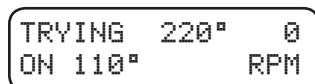

- 11.2 The first parameter view screen identifies the solenoid valve outputs which are being energized. The #1 and #2 depict the two connectors of the 20 output module. Only the top line will be displayed for the 10 output module. In the example shown, output pin A and B of connector #1 and pin A of connector #2 are turned on.

Press NEXT

```
#1 AB-----
#2 A-----
```

- 11.3 The second parameter view screen provides a flux magnitude value which can be helpful in diagnosing a mis-assembled Electronic Air Start Distributor. The bottom line of the active home screen is replaced as shown below. Acceptable flux values are from 5 to 25 and not varying more than 5 in a single rotation.

Press NEXT

```
TRYING 220° 0
EncoderFlux 14
```

- 11.4 The next parameter view screen provides the system supply voltage value which can be helpful in diagnosing installation or supply voltage problems. The bottom line of the active home screen is replaced as shown below.

Press NEXT

```
TRYING 220° 0
Supply 24.2volts
```

- 11.5 The final parameter view screen provides a voltage and current description of the analog air pressure sensor input. These values can be helpful in diagnosing and calibrating the air pressure sensor. The bottom line of the active home screen is replaced as shown below.

Press NEXT

```
TRYING 220° 0
Air0.00V/ 0.03ma
```

- 11.6 Pressing **NEXT** again returns the screen as shown in 11.1.

12.0 TEST MODE DIAGNOSTIC FUNCTION SCREEN

- 12.1 The Test Mode diagnostic function can be used to actuate all of the outputs or a specific output for the purpose of troubleshooting the valve wiring. From the READY home screen press **SETUP** to access the test mode screen and use the plus/minus keys to activate and select the Test Mode.

```
READY 220° 0
WAIT=DIGopen
```

Press SETUP

```
TestMode
→ OFF
```

- 12.2 The ALL Test Mode will pulse all of the valves in order, switching to the next valve each ~200mS and keeping the valve on for ~50mS.

Press +

```
TestMode
→ ALL (In Order)
```

12.3 The individual output Test Mode will pulse a specific valve every ~200mS for ~50mS.

Press +

```
TestMode
Pulsing Pin → A
```

Press +

```
TestMode
Pulsing Pin → B
```

12.4 Operation of the Test Mode will be terminated by detection of engine rotation, by any status change from the READY state, or by pressing the **NORM** key. Operation of Test Mode will time out after 10 minutes of no key activity. The NotRDY message shown below will indicate that the test mode is inhibited because the status is not READY.

```
TestMode
OFF (NotRDY)
```

13.0 USING THE SAVEAIR TERMINAL PC PROGRAM

- 13.1 Included with the SaveAir system is an optional use PC Terminal Program. The terminal program may be used to program and troubleshoot an installation initially or it can be used to monitor the operation via a personal computer on a long term basis. The terminal program is stored on the CDrom disc (PN 609019) shipped with the SaveAir system and will auto-install on an IBM-compatible computer using any of these Windows® operating systems: 98, ME, XP, 2000, Vista, Win 7, and Win 7-64-bit.
- 13.2 The SaveAir Electronic Air Start Distributor includes one half-duplex RS-485 9600,N,8,1 communications port which always functions as a MODBUS slave that can support ONE master device.
- 13.3 The Display Module, PC Terminal Program or MODBUS equipped PLC will always function as the communications master. One and only one master is permitted on the bus at a time. Therefore, the Display Module must be disconnected anytime an alternate device such as a PC or PLC is in use.
- 13.4 An RS-485 adapter is required to connect the PC to the SaveAir serial port. The recommended RS-232 to RS-485 converter is the B&B Electronics Model 4WSD9R with switches set as follows (RS-485, EchoOFF, 2wire, 2wire).
- 13.5 The operation of the terminal program is, for the most part, self-evident. Where additional information would be helpful to the first time user, it is included as Windows Tool Tips. These tips are ballooned text messages which appear when the mouse pointer is hovered over various target items of the screen.
- 13.6 Menu activated advanced user features are listed below.

CHART	Real time graphical display of starter related data.
ROI	Remote Operator Interface - Display Module emulation.
DEVICE CONFIG	Save, Read, Send Configuration Data Files.
SNAPSHOT	Save snapshot of current screen to .jpg file.
LOGFILE	Save real time starter data to comma delimited .csv file.

14.0 MODBUS REGISTER LIST

REG00001	“Test Digital In 1 Permissive “
REG00002	“Test Air Pressure Permissive “
REG00003	“Engine Type 1=4cycle 0=2cycle “
REG00004	“InputShaft Rotation 1=CW 0=CCW”
REG00005	“RESERVED “
REG00006	“RESERVED “
REG00007	“RESERVED “
REG00008	“ROI active on RTU port 1=ON “
REG00009	“RESERVED “
REG00010	“RESERVED “
REG00011	“RESERVED “
REG00012	“RESERVED “
REG00013	“RESERVED “
REG00014	“RESERVED “
REG00015	“RESERVED “
REG00016	“RESERVED “
REG10001	“Digital Input #1 Inhibit”
REG10002	“Air Supply Pressure Inhibit”
REG10003	“Duration vs RPM = 0 Inhibit”
REG10004	“Restart Inhibit”
REG10005	“Energizing Solenoids Now “
REG10006	“Digital In #1 Grounded Status “
REG10007	“Air Supply>start Status “
REG10008	“Air Supply>stop Status “
REG10009	“CFGERR TDC Tbl AngleOrderEven”
REG10010	“CFGERR TDC Tbl AngleOrderOdd “
REG10011	“CFGERR INITIATE Tbl RPM order”
REG10012	“CFGERR DURATION Tbl RPM order”
REG10013	“CFGERR Air.Start < Air Stop “
REG10014	“FluxLO Magnet Gap too small”
REG10015	“FluxHI Magnet Gap too large”
REG10016	“FluxDELTA Magnet Off Center “
REG10017	“MUX ac A PIN AT MICRO WIRE=K”
REG10018	“MUX ac B PIN AT MICRO WIRE=L”
REG10019	“MUX ac C PIN AT MICRO WIRE=M”
REG10020	“MUX bd A PIN AT MICRO WIRE=N”
REG10021	“MUX bd B PIN AT MICRO WIRE=P”
REG10022	“MUX bd C PIN AT MICRO WIRE=R”
REG10023	“Purged Output Pin WIRE=?”
REG10024	“Running “
REG10025	“FIREA PIN AT MICRO WIRE=A”
REG10026	“FIREB PIN AT MICRO WIRE=B”

14.0 MODBUS REGISTER LIST (continued)

REG10027	"FIREC PIN AT MICRO WIRE=C"
REG10028	"FIRED PIN AT MICRO WIRE=D"
REG10029	"Valve Output 1 Harness Pin 1A"
REG10030	"Valve Output 2 Harness Pin 2A"
REG10031	"Valve Output 3 Harness Pin 1B"
REG10032	"Valve Output 4 Harness Pin 2B"
REG10033	"Valve Output 5 Harness Pin 1C"
REG10034	"Valve Output 6 Harness Pin 2C"
REG10035	"Valve Output 7 Harness Pin 1D"
REG10036	"Valve Output 8 Harness Pin 2D"
REG10037	"Valve Output 9 Harness Pin 1E"
REG10038	"Valve Output 10 Harness Pin 2E"
REG10039	"Valve Output 11 Harness Pin 1F"
REG10040	"Valve Output 12 Harness Pin 2F"
REG10041	"Valve Output 13 Harness Pin 1K"
REG10042	"Valve Output 14 Harness Pin 2K"
REG10043	"Valve Output 15 Harness Pin 1L"
REG10044	"Valve Output 16 Harness Pin 2L"
REG10045	"Valve Output 17 Harness Pin 1M"
REG10046	"Valve Output 18 Harness Pin 2M"
REG10047	"Valve Output 19 Harness Pin 1N"
REG10048	"Valve Output 20 Harness Pin 2N"
REG10049	"EEUPDATED time to read 4xxxx's"
REG10050	"RESERVED "
REG10051	"RESERVED "
REG10052	"RESERVED "
REG10053	"RESERVED "
REG10054	"RESERVED "
REG10055	"RESERVED "
REG10056	"RESERVED "
REG10057	"RESERVED "
REG10058	"RESERVED "
REG10059	"RESERVED "
REG10060	"RESERVED "
REG10061	"RESERVED "
REG10062	"RESERVED "
REG10063	"RESERVED "
REG10064	"RESERVED "
REG30001	"mirror of inputs 10016-10001 "
REG30002	"mirror of inputs 10032-10017 "
REG30003	"mirror of inputs 10048-10033 "
REG30004	"mirror of inputs 10064-10049 "

REG30005	"mirror of inputs 10080-10065 "
REG30006	"mirror of inputs 10096-10081 "
REG30007	"mirror of inputs 10112-10097 "
REG30008	"mirror of inputs 10128-10113 "
REG30009	"Electronic Air Start STAT code"
REG30010	"Electronic Air Start WAIT code"
REG30011	"ENCODER ANGLE DEG"
REG30012	"ENCODER FLUX (0-31)"
REG30013	"Engine Angle DEG"
REG30014	"Engine RPM RPM"
REG30015	"INITIATE Angle DEG"
REG30016	"DURATION Angle DEG"
REG30017	"Air Sensor Voltage volts*100"
REG30018	"Air Sensor Current mA*100"
REG30019	"Air Sensor Pressure psig*10"
REG30020	"SUPPLY VOLTAGE 24V volts*10"
REG30021	"CYCLE COUNTER cycles "
REG30022	"Electronic Air Start STOP=code"
REG30023	"Electronic Air Start STOP@code"
REG30024	"Aux 1 Signal Output mA*100"
REG30025	"Aux 2 Signal Output mA*100"
REG40001	"mirror of coils 00016-00001 " LIM={00000,65535} DEF=(1)
REG40002	"mirror of coils 00032-00017 " LIM={00000,65535}
REG40003	"mirror of coils 00048-00033 " LIM={00000,65535}
REG40004	"mirror of coils 00064-00049 " LIM={00000,65535}
REG40005	"mirror of coils 00080-00065 " LIM={00000,65535}
REG40006	"mirror of coils 00096-00081 " LIM={00000,65535}
REG40007	"mirror of coils 00112-00097 " LIM={00000,65535}
REG40008	"mirror of coils 00128-00113 " LIM={00000,65535}
REG40009	"NUMBER OF OUTPUTS USED " LIM={ 3, 20} DEF=(8)
REG40010	"ENCODER CAL ANGLE " LIM={ 0, 719} DEF=(0)
REG40011	"Min Speed for Valid Purge RPM" LIM={ 0, 200} DEF=(30)
REG40012	"Cycles to Purge CYC" LIM={ 0, 20} DEF=(4)
REG40013	"AirOff Cycles Before Run CYC" LIM={ 0, 500} DEF={ 30}
REG40014	"Output Module Type dash 1 or 2" LIM={ 1, 2} DEF={ 1}
REG40015	"Air Supply Start > xxx.x psi" LIM={00000,32767} DEF={ 1000}
REG40016	"Air Supply Stop < xxx.x psi" LIM={00000,32767} DEF={ 800}
REG40017	"Air Supply Reset < xxx.x psi" LIM={00000,32767} DEF={ 50}
REG40018	"Air Supply Pres Sensor Span " LIM={ 1,32767} DEF={ 7813}
REG40019	"Air Supply Pres Sensor Zero " LIM={-32768,32767}DEF={-1250}
REG40020	"TDC OF CYL01/OUTPUT A OR 1A " LIM={ 0, 720} DEF={ 0}
REG40021	"TDC OF CYL02/OUTPUT B OR 2A " LIM={ 0, 720} DEF={ 45}

14.0 MODBUS REGISTER LIST (continued)

REG40022	"TDC OF CYL03/OUTPUT C OR 1B " LIM={ 0, 720} DEF={ 90}
REG40023	"TDC OF CYL04/OUTPUT D OR 2B " LIM={ 0, 720} DEF={ 135}
REG40024	"TDC OF CYL05/OUTPUT E OR 1C " LIM={ 0, 720} DEF={ 180}
REG40025	"TDC OF CYL06/OUTPUT F OR 2C " LIM={ 0, 720} DEF={ 225}
REG40026	"TDC OF CYL07/OUTPUT G OR 1D " LIM={ 0, 720} DEF={ 270}
REG40027	"TDC OF CYL08/OUTPUT H OR 2D " LIM={ 0, 720} DEF={ 315}
REG40028	"TDC OF CYL09/OUTPUT J OR 1E " LIM={ 0, 720} DEF={ 720}
REG40029	"TDC OF CYL10/OUTPUT K OR 2E " LIM={ 0, 720} DEF={ 720}
REG40030	"TDC OF CYL11/OUTPUT 1F " LIM={ 0, 720} DEF={ 720}
REG40031	"TDC OF CYL12/OUTPUT 2F " LIM={ 0, 720} DEF={ 720}
REG40032	"TDC OF CYL13/OUTPUT 1G " LIM={ 0, 720} DEF={ 720}
REG40033	"TDC OF CYL14/OUTPUT 2G " LIM={ 0, 720} DEF={ 720}
REG40034	"TDC OF CYL15/OUTPUT 1H " LIM={ 0, 720} DEF={ 720}
REG40035	"TDC OF CYL16/OUTPUT 2H " LIM={ 0, 720} DEF={ 720}
REG40036	"TDC OF CYL17/OUTPUT 1J " LIM={ 0, 720} DEF={ 720}
REG40037	"TDC OF CYL18/OUTPUT 2J " LIM={ 0, 720} DEF={ 720}
REG40038	"TDC OF CYL19/OUTPUT 1K " LIM={ 0, 720} DEF={ 720}
REG40039	"TDC OF CYL20/OUTPUT 2K " LIM={ 0, 720} DEF={ 720}
REG40040	"INITIATE TABLE POINT 1 RPM " LIM={ -1, 0} DEF={ 0}
REG40041	"INITIATE TABLE POINT 1 DEG " LIM={ -300, 300} DEF={ 5}
REG40042	"INITIATE TABLE POINT 2 RPM " LIM={ -1, 500} DEF={ 10}
REG40043	"INITIATE TABLE POINT 2 DEG " LIM={ -300, 300} DEF={ 5}
REG40044	"INITIATE TABLE POINT 3 RPM " LIM={ 0, 500} DEF={ 20}
REG40045	"INITIATE TABLE POINT 3 DEG " LIM={ -300, 300} DEF={ 5}
REG40046	"INITIATE TABLE POINT 4 RPM " LIM={ 0, 500} DEF={ 30}
REG40047	"INITIATE TABLE POINT 4 DEG " LIM={ -300, 300} DEF={ 5}
REG40048	"INITIATE TABLE POINT 5 RPM " LIM={ 1, 500} DEF={ 40}
REG40049	"INITIATE TABLE POINT 5 DEG " LIM={ -10, 180} DEF={ 5}
REG40050	"INITIATE TABLE POINT 6 RPM " LIM={ 1, 500} DEF={ 60}
REG40051	"INITIATE TABLE POINT 6 DEG " LIM={ -10, 180} DEF={ 5}
REG40052	"INITIATE TABLE POINT 7 RPM " LIM={ 1, 500} DEF={ 75}
REG40053	"INITIATE TABLE POINT 7 DEG " LIM={ -10, 180} DEF={ 5}
REG40054	"INITIATE TABLE POINT 8 RPM " LIM={ 1, 500} DEF={ 100}
REG40055	"INITIATE TABLE POINT 8 DEG " LIM={ -10, 180} DEF={ 5}
REG40056	"INITIATE TABLE POINT 9 RPM " LIM={ 1, 500} DEF={ 125}
REG40057	"INITIATE TABLE POINT 9 DEG " LIM={ -10, 180} DEF={ 5}
REG40058	"INITIATE TABLE POINT 10 RPM " LIM={ 1, 500} DEF={ 150}
REG40059	"INITIATE TABLE POINT 10 DEG " LIM={ -10, 180} DEF={ 5}
REG40060	"DURATION TABLE POINT 1 RPM " LIM={ -1, 0} DEF={ 0}
REG40061	"DURATION TABLE POINT 1 DEG " LIM={ 0, 300} DEF={ 105}
REG40062	"DURATION TABLE POINT 2 RPM " LIM={ -1, 500} DEF={ 10}
REG40063	"DURATION TABLE POINT 2 DEG " LIM={ 0, 300} DEF={ 100}

REG40064	"DURATION TABLE POINT 3 RPM " LIM={ 0, 500} DEF={ 20}
REG40065	"DURATION TABLE POINT 3 DEG " LIM={ 0, 300} DEF={ 90}
REG40066	"DURATION TABLE POINT 4 RPM " LIM={ 0, 500} DEF={ 30}
REG40067	"DURATION TABLE POINT 4 DEG " LIM={ 0, 300} DEF={ 80}
REG40068	"DURATION TABLE POINT 5 RPM " LIM={ 1, 500} DEF={ 40}
REG40069	"DURATION TABLE POINT 5 DEG " LIM={ 0, 180} DEF={ 80}
REG40070	"DURATION TABLE POINT 6 RPM " LIM={ 1, 500} DEF={ 60}
REG40071	"DURATION TABLE POINT 6 DEG " LIM={ 0, 180} DEF={ 80}
REG40072	"DURATION TABLE POINT 7 RPM " LIM={ 1, 500} DEF={ 75}
REG40073	"DURATION TABLE POINT 7 DEG " LIM={ 0, 180} DEF={ 50}
REG40074	"DURATION TABLE POINT 8 RPM " LIM={ 1, 500} DEF={ 100}
REG40075	"DURATION TABLE POINT 8 DEG " LIM={ 0, 180} DEF={ 0}
REG40076	"DURATION TABLE POINT 9 RPM " LIM={ 1, 500} DEF={ 125}
REG40077	"DURATION TABLE POINT 9 DEG " LIM={ 0, 180} DEF={ 0}
REG40078	"DURATION TABLE POINT 10 RPM " LIM={ 1, 500} DEF={ 150}
REG40079	"DURATION TABLE POINT 10 DEG " LIM={ 0, 180} DEF={ 0}

SAVE *Air* Setup and Configuration WorkSheet

Customer: _____ Station: _____
 Engine Model: _____ Unit No. _____
 Installer: _____ Date: _____

Logic/Distribution Model: 291300- _____ SN: _____
 Output Module Model: 291301- _____ SN: _____
 Display Module Model: 201302-1 SN: _____

<u>ENGINE CFG:</u>	<u>TDC PATTERN TBL:</u>	<u>INITIATE TBL:</u>
LineUpCal = _____	PIN ANGLE CYLINDER	#1 _____ rpm _____ deg
Module = _____	#1 A(A1) _____ deg _____ cyl	#2 _____ rpm _____ deg
NumValves = _____	#2 B(A2) _____ deg _____ cyl	#3 _____ rpm _____ deg
CW / CCW = _____	#3 C(B1) _____ deg _____ cyl	#4 _____ rpm _____ deg
4Cyc/2Cyc = _____	#4 D(B2) _____ deg _____ cyl	#5 _____ rpm _____ deg
InhibitDIG = _____	#5 E(C1) _____ deg _____ cyl	#6 _____ rpm _____ deg
InhibitAIR = _____	#6 F(C2) _____ deg _____ cyl	#7 _____ rpm _____ deg
PurgeRPM = _____	#7 G(D1) _____ deg _____ cyl	#8 _____ rpm _____ deg
PurgeCycles = _____	#8 H(D2) _____ deg _____ cyl	#9 _____ rpm _____ deg
RunCycles = _____	#9 J(E1) _____ deg _____ cyl	#10 _____ rpm _____ deg
	#10 K(E2) _____ deg _____ cyl	
<u>SENSOR CFG:</u>	#11 (F1) _____ deg _____ cyl	<u>DURATION TBL:</u>
Air.Start = _____	#12 (F2) _____ deg _____ cyl	#1 _____ rpm _____ deg
Air Stop = _____	#13 (G1) _____ deg _____ cyl	#2 _____ rpm _____ deg
Air Reset = _____	#14 (G2) _____ deg _____ cyl	#3 _____ rpm _____ deg
Air.Span = _____	#15 (H1) _____ deg _____ cyl	#4 _____ rpm _____ deg
Air.Zero = _____	#16 (H2) _____ deg _____ cyl	#5 _____ rpm _____ deg
	#17 (J1) _____ deg _____ cyl	#6 _____ rpm _____ deg
	#18 (J2) _____ deg _____ cyl	#7 _____ rpm _____ deg
	#19 (K1) _____ deg _____ cyl	#8 _____ rpm _____ deg
	#20 (K2) _____ deg _____ cyl	#9 _____ rpm _____ deg
		#10 _____ rpm _____ deg

FIGURES:

- FIGURE 1 SAVEAIR OUTPUT MODULE, 291301-1 (10 OUTPUT)
- FIGURE 2 SAVEAIR OUTPUT MODULE, 291301-2, (20 OUTPUT)
- FIGURE 3 SAVEAIR DISPLAY MODULE, 291302-1
- FIGURE 4 SAVEAIR LOGIC/DISTRIBUTION MODULE, 291310-xx
- FIGURE 5 VALVE, 3-WAY SOLENOID, 690017-1
- FIGURE 6 VALVE, 3-WAY QUICK EXHAUST SOLENOID, 690017-2
- FIGURE 7 RELAY VALVE ASSEMBLY KIT, 690018-1, SAVEAIR, CLARK ENGINE
- FIGURE 8 SAVEAIR WIRING DIAGRAM, 10 SOLENOID OUTPUTS
- FIGURE 9 SAVEAIR WIRING DIAGRAM, 20 SOLENOID OUTPUTS
- FIGURE 10 SAVEAIR WIRING DIAGRAM, DISPLAY AND I/O
- FIGURE 11 SHIELDED HARNESS, 293034
- FIGURE 12 SHIELDED HARNESS, 293031
- FIGURE 13 SHIELDED HARNESS, 293036-24, 48, 72
- FIGURE 14 SHIELDED HARNESS CONDUIT LENGTH ADJUSTMENT
- FIGURE 15 HOME SCREEN STATUS MESSAGES
- FIGURE 16 CONFIGURATION SCREENS

FIGURE 1 – SAVEAIR OUTPUT MODULE 291301-1 (10 OUTPUT)

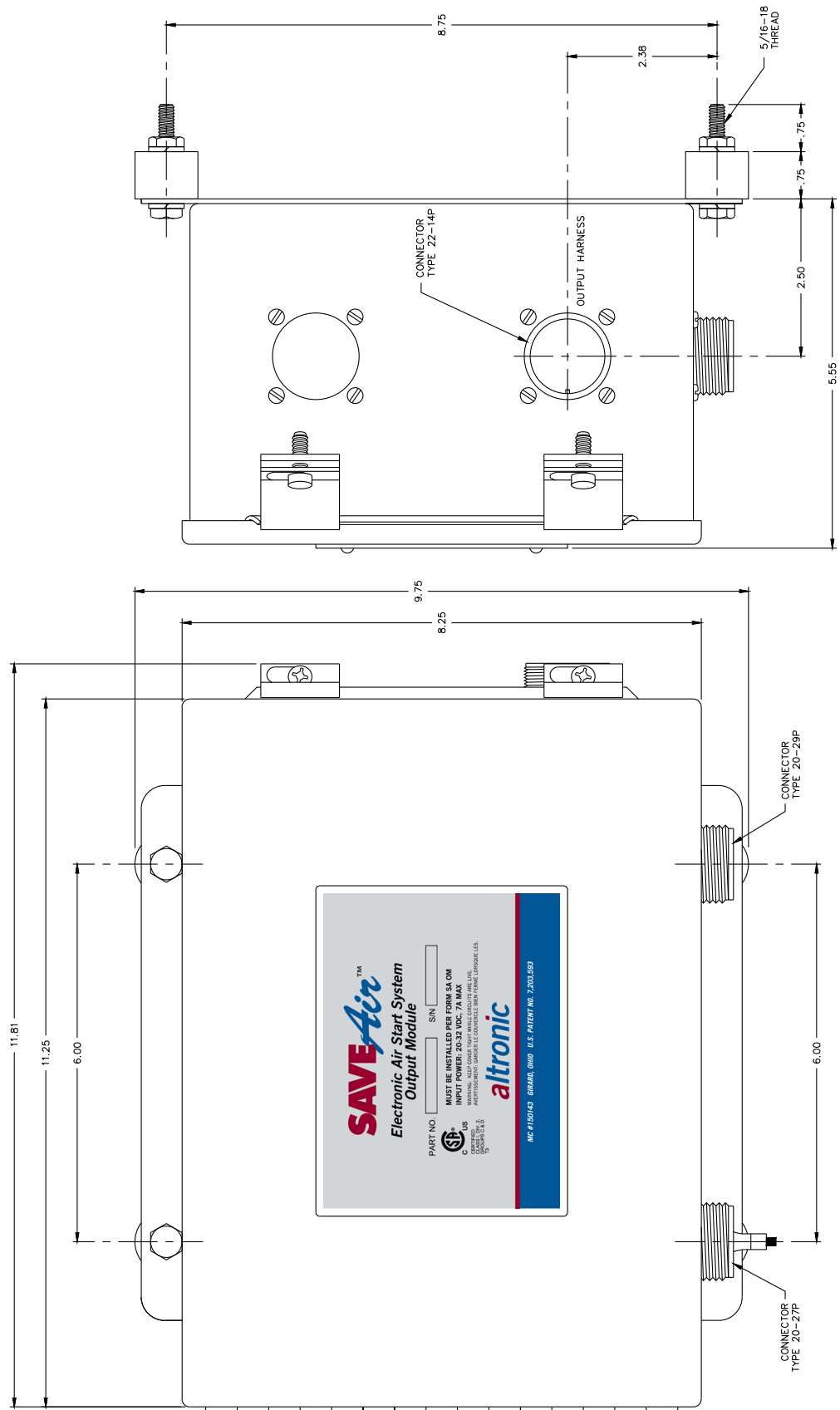

FIGURE 2 – SAVEAIR OUTPUT MODULE 291301-2, (20 OUTPUT)

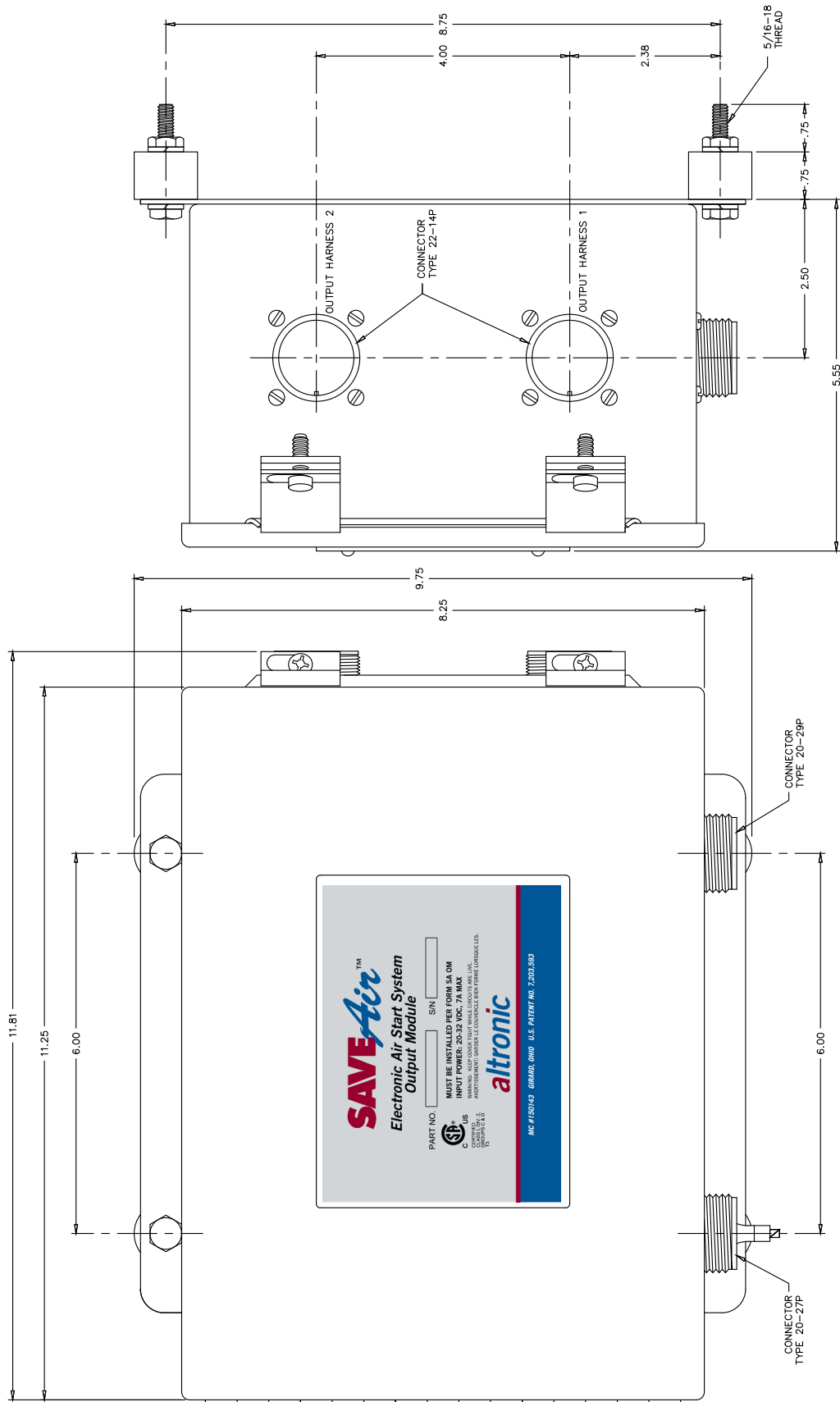

FIGURE 3 – SAVEAIR DISPLAY MODULE 291302-1, SAVEAIR

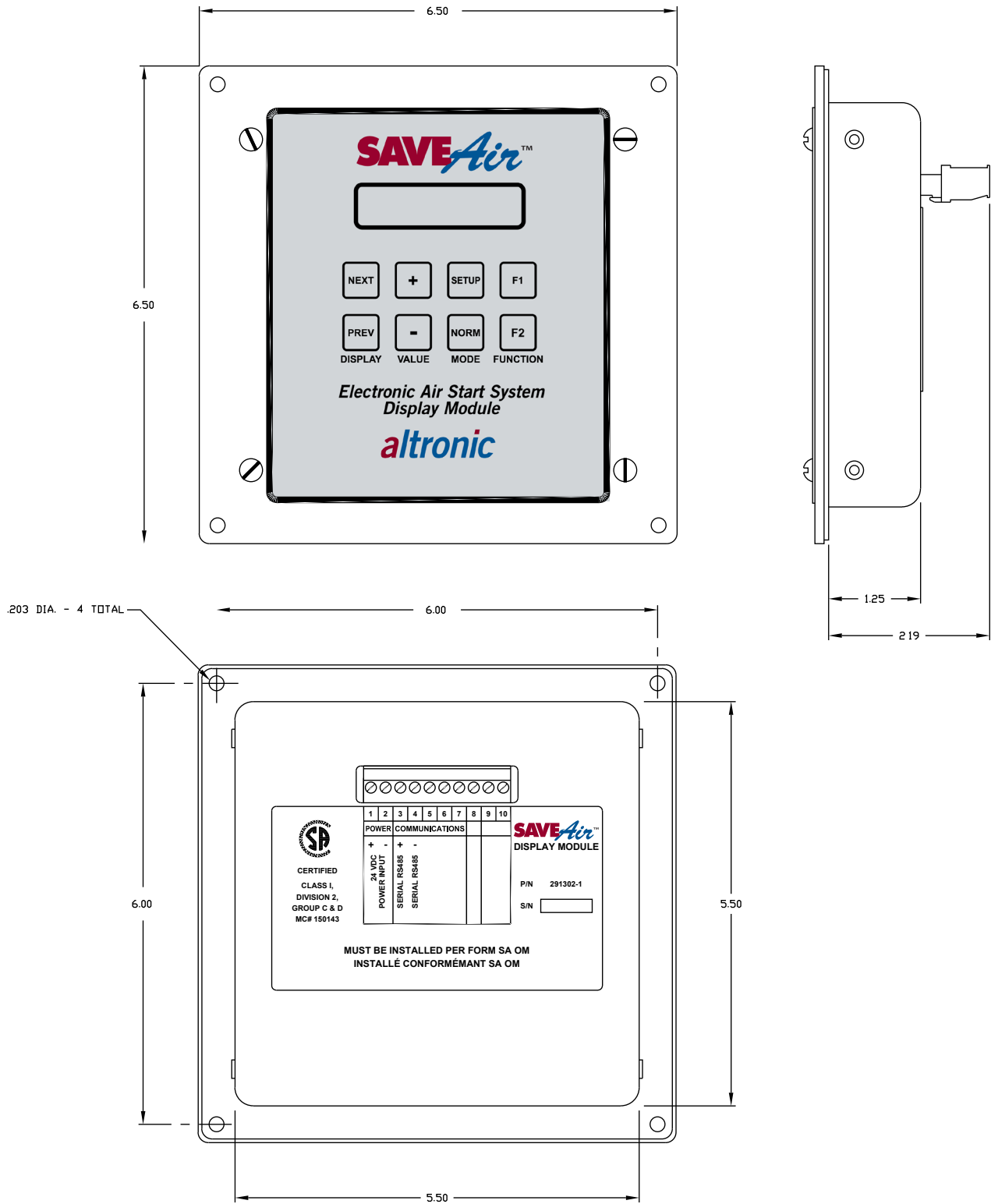

FIGURE 4 – SAVEAIR ELECTRONIC AIR START DISTRIBUTOR 291310-xx

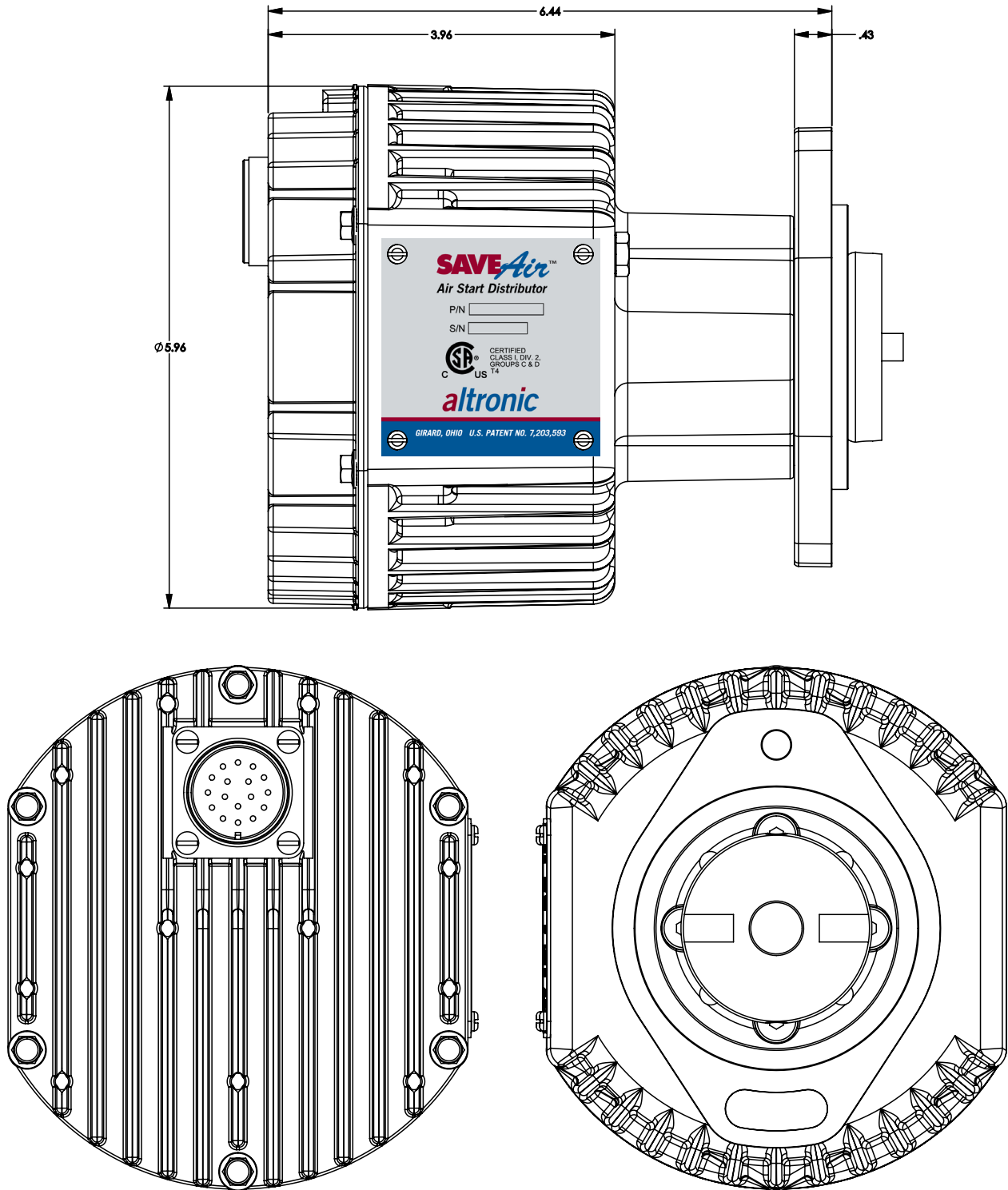
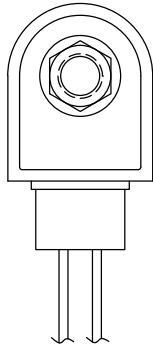
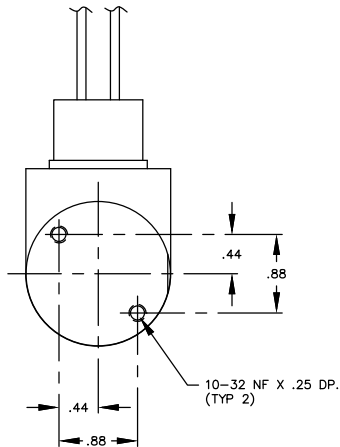
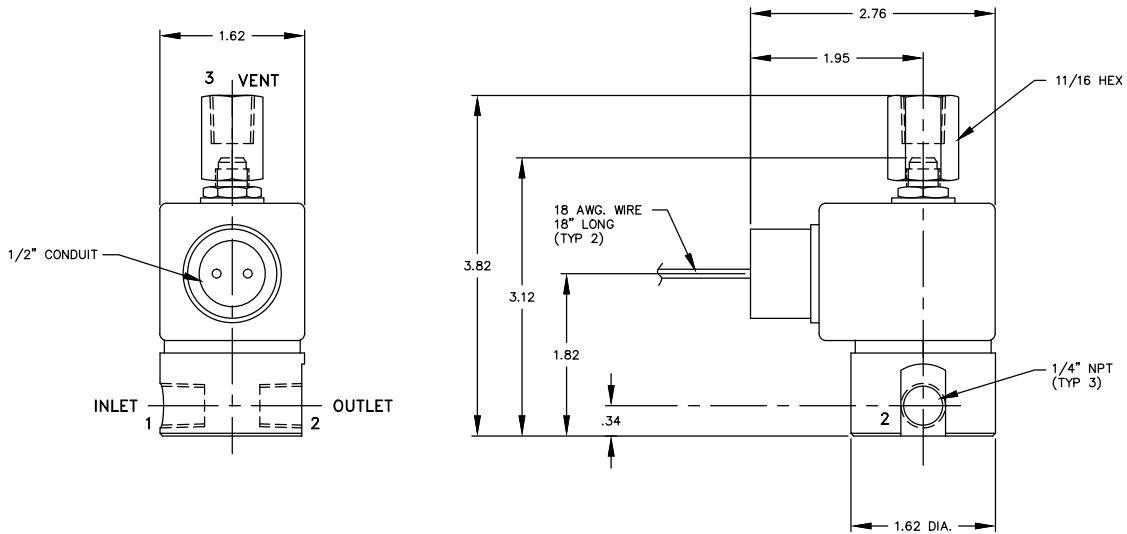

FIGURE 5 – VALVE, 3-WAY SOLENOID, 690017-1



SPECIFICATIONS

VOLTAGE: 24V +10%, -15%
 WATTS: 10
 MAX. PRESSURE: 250 PSI
 ORIFICE SIZE: 3/64", 1/16" DIA.
 DIRECT OPERATED: NORMALLY CLOSED
 OPERATING TEMP.: -40°C TO +65°C
 COIL RESISTANCE: 59.3 ± 8% OHMS
 PORT THREAD SPEC: 1/4" NPT
 BODY MATERIAL: 430 SS



NOTES:

1. A SUBSTITUTE ITEM SHALL NOT BE USED WITHOUT PRIOR QUALIFICATION BY ALTRONIC, LLC (ENGINEERING DEPT.)
2. VENDOR CHANGE CONTROL AND TRACEABILITY PER SPECIFICATION 5001616.
3. VALVE MUST BE CSA APPROVED FOR HAZARDOUS LOCATIONS.

FIGURE 6 – VALVE, 3-WAY QUICK EXHAUST SOLENOID, 690017-2

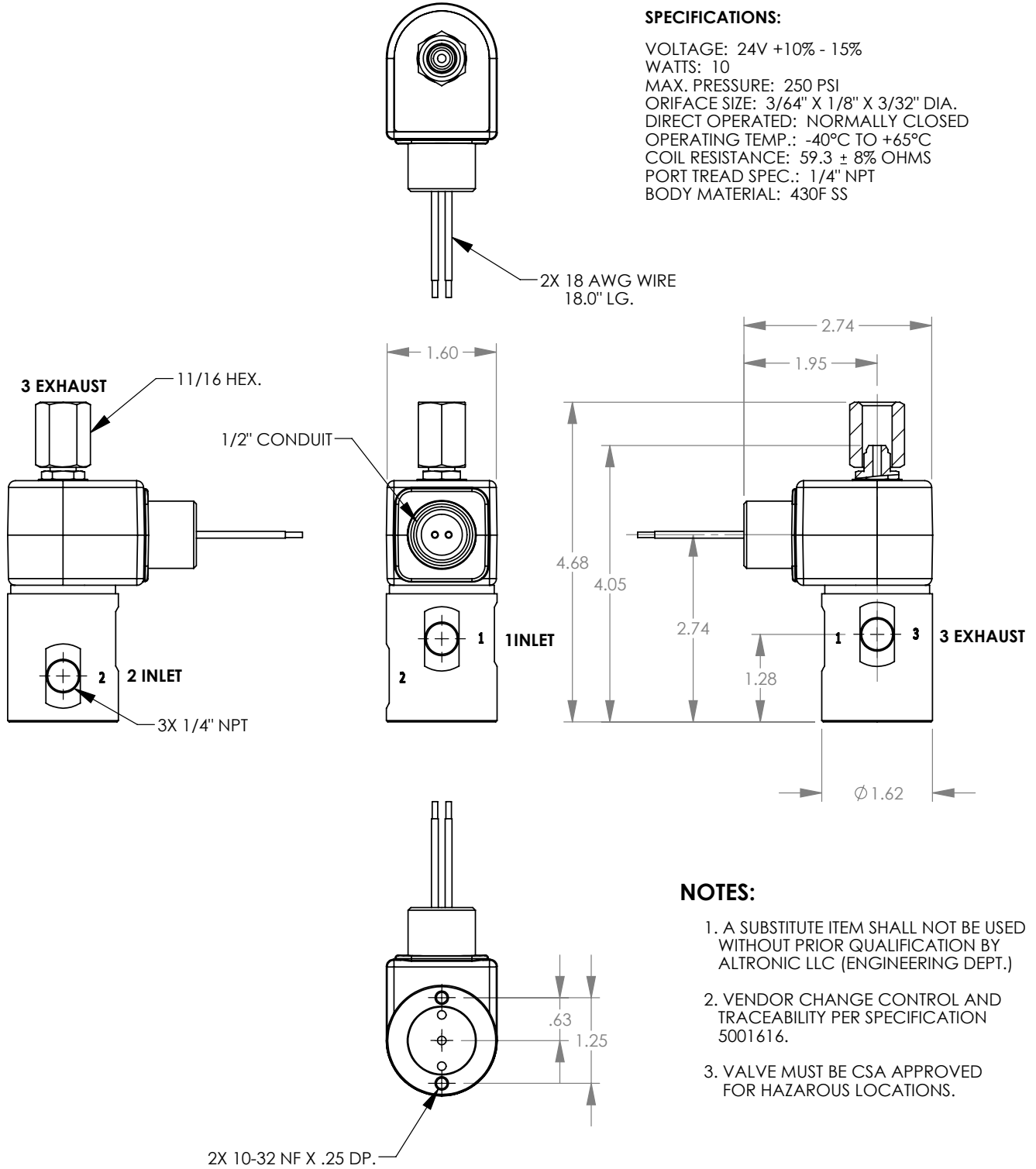

FIGURE 7 – RELAY VALVE ASSEMBLY KIT, 690018-1, SAVEAIR, CLARK ENGINE

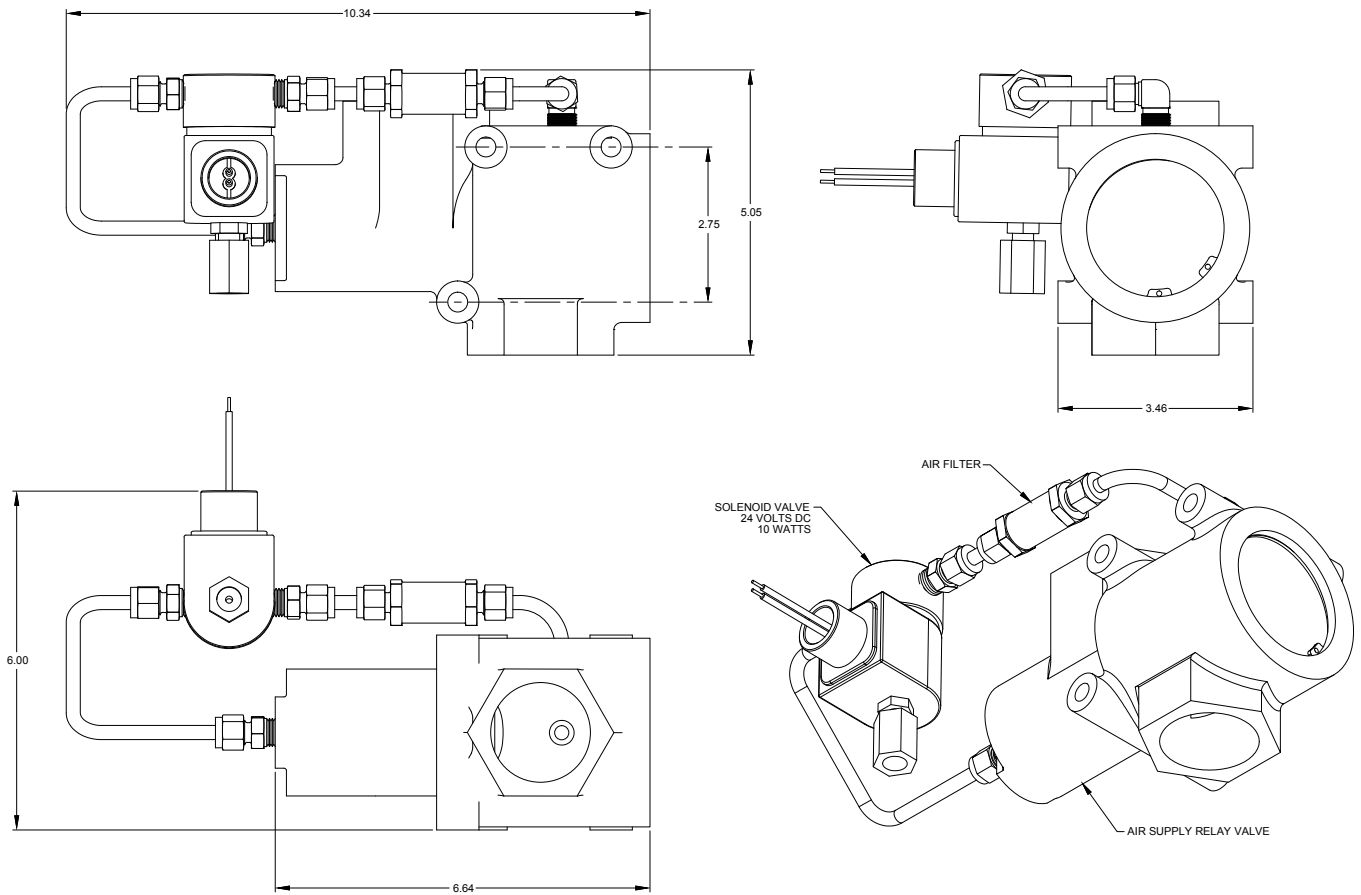

FIGURE 8 – WIRING DIAGRAM, SAVEAIR 10 SOLENOID OUTPUTS

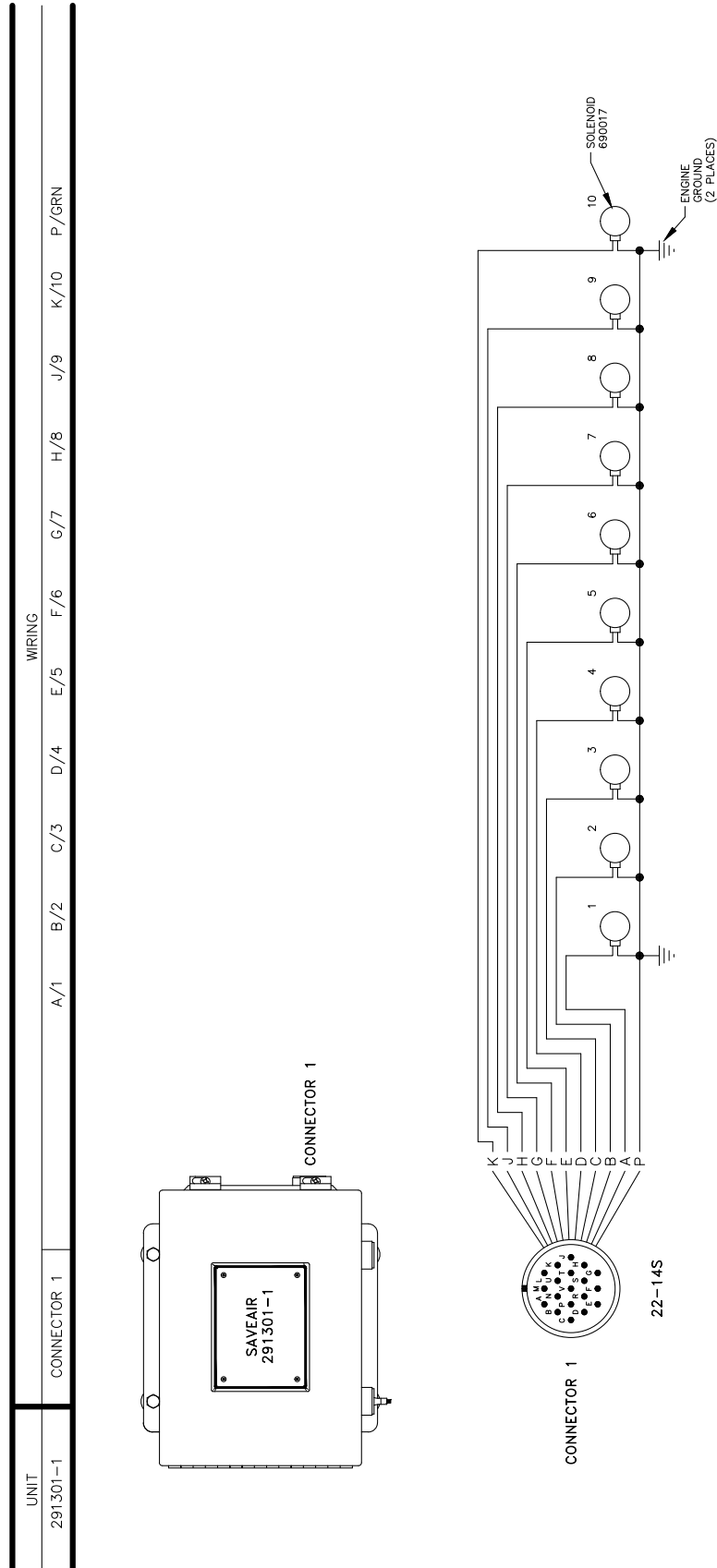

FIGURE 9 – WIRING DIAGRAM, SAVEAIR 20 SOLENOID OUTPUTS

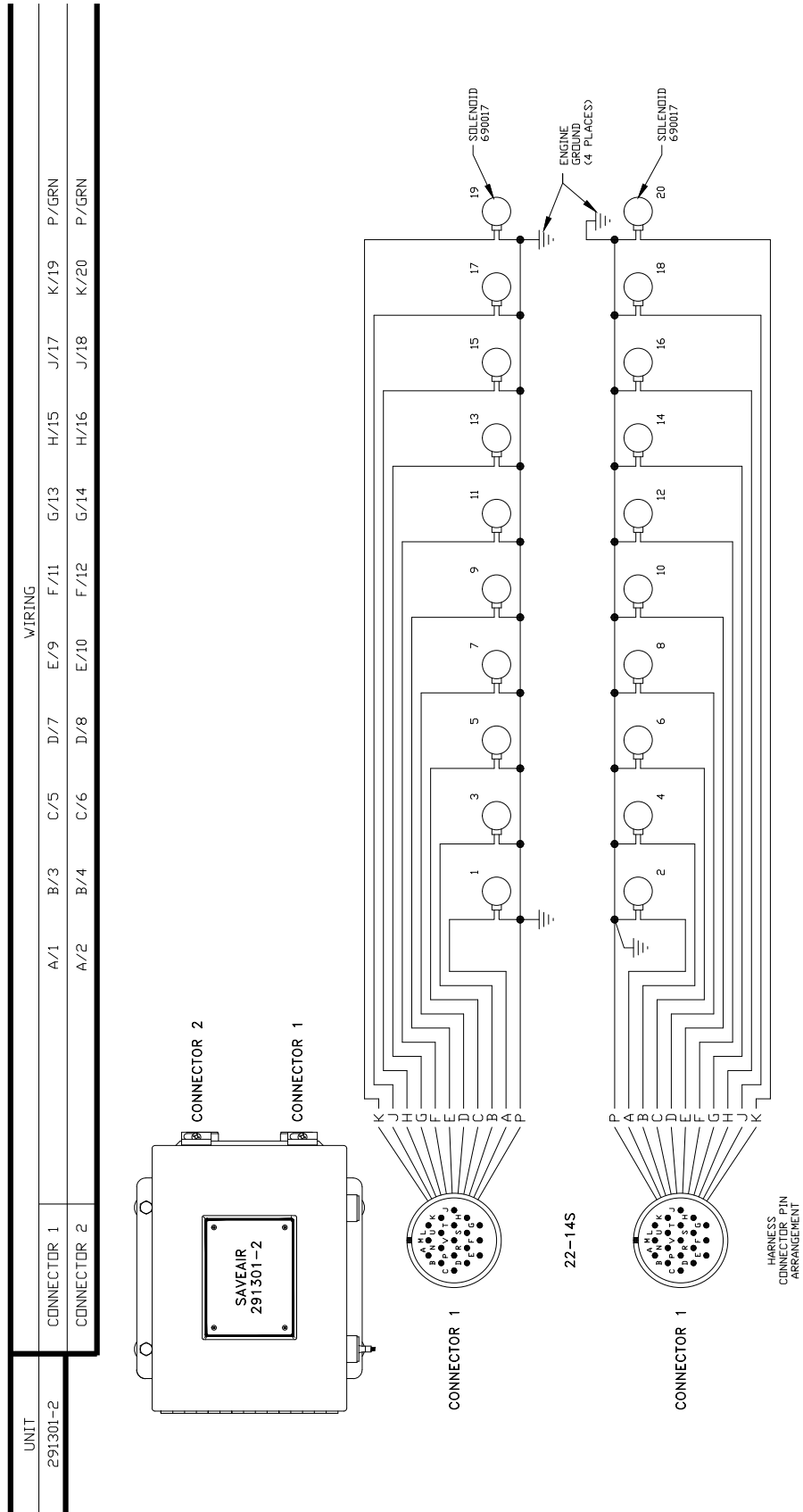

FIGURE 10 – WIRING DIAGRAM, SAVEAIR DISPLAY AND I/O

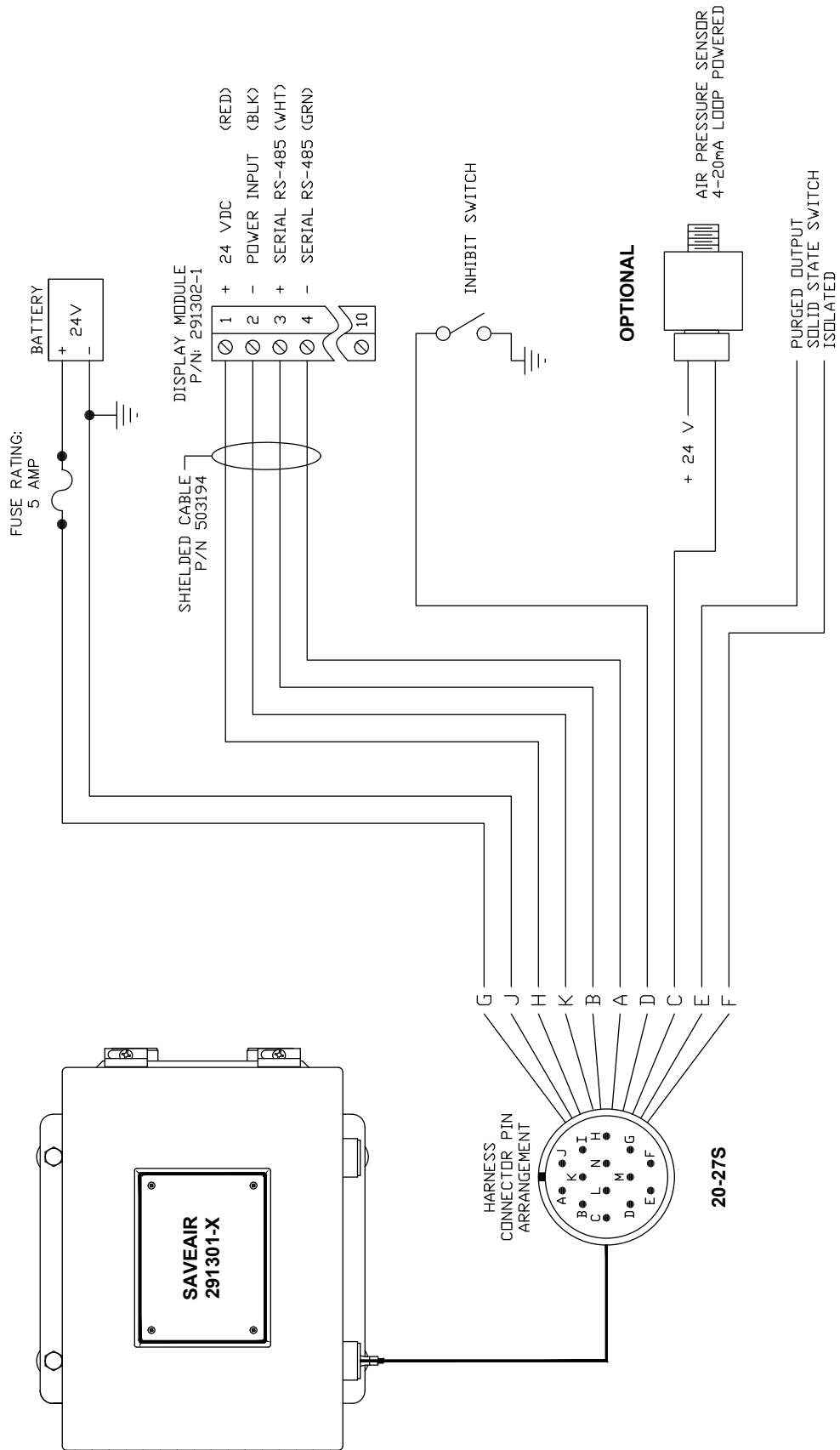

FIGURE 11 – SHIELDED HARNESS, 293034

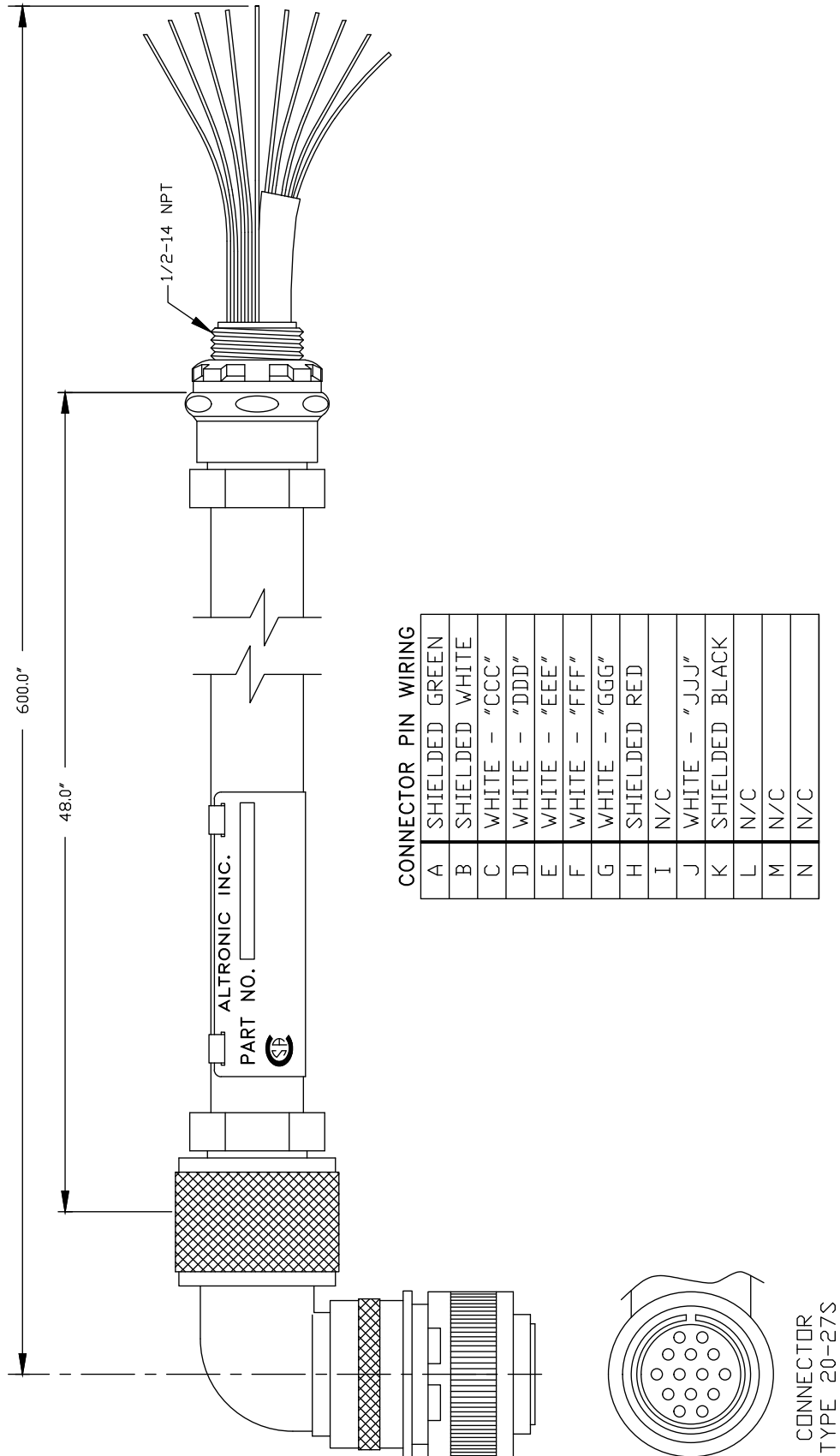
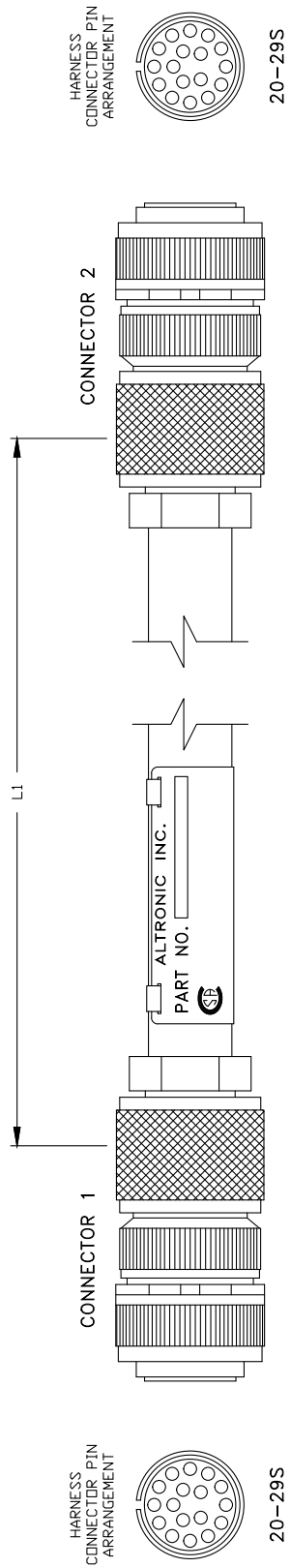

FIGURE 12 – SHIELDED HARNESS, 293031



PART NO.	L1 LENGTH
293031-24	24"
293031-48	48"
293031-72	72"

CONNECTOR 1 PIN	CONNECTOR 2 PIN
A	A
B	B
C	C
D	D
E	E
F	F
G	G
H	H
J	J
K	K
L	L
M	M
N	N
P	P
R	R
S	S
T	T

FIGURE 13 – SHIELDED HARNESS, 293036-24, 48, 72

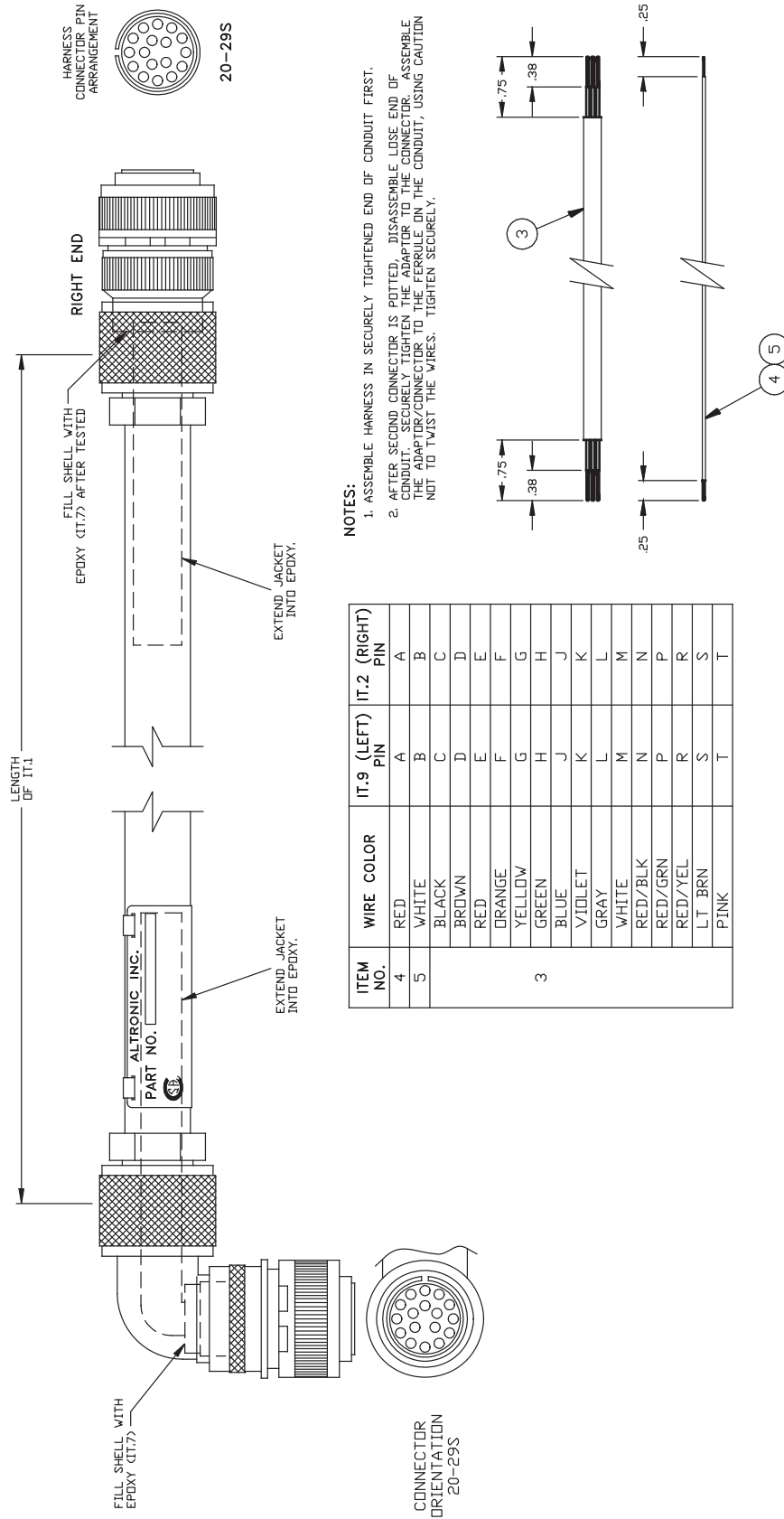

- NOTES:**
1. ASSEMBLE HARNESS IN SECURELY TIGHTENED END OF CONDUIT FIRST.
 2. AFTER SECOND CONNECTOR IS POTTED, DISASSEMBLE LOOSE END OF CONDUIT. SECURELY TIGHTEN THE ADAPTOR TO THE CONNECTOR. ASSEMBLE THE ADAPTOR/CONNECTOR TO THE FERRULE ON THE CONDUIT, USING CAUTION NOT TO TWIST THE WIRES. TIGHTEN SECURELY.

ITEM NO.	WIRE COLOR	IT.9 (LEFT) PIN	IT.2 (RIGHT) PIN
4	RED	A	A
5	WHITE	B	B
3	BLACK	C	C
	BROWN	D	D
	RED	E	E
	ORANGE	F	F
	YELLOW	G	G
	GREEN	H	H
	BLUE	J	J
	VIOLET	K	K
	GRAY	L	L
	WHITE	M	M
	RED/BLK	N	N
	RED/GRN	P	P
	RED/YEL	R	R
	LT. BRN	S	S
PINK	T	T	

FIGURE 14 – SHIELDED HARNESS CONDUIT LENGTH ADJUSTMENT

TO SHORTEN HARNESS

1. LOOSEN AND DISENGAGE NUT (2) AND REMOVE CONDUIT (1) COMPLETELY FROM CONNECTOR AND HARNESS ASSEMBLY (3).
2. REMOVE ITEMS (5), (4), AND (2) IN THAT ORDER FROM CONDUIT (1). NOTE THREADS ON (5).
3. CUT CONDUIT TO LENGTH WITH HACKSAW AND DRESS WITH FILE TO INSURE A CLEAN, SQUARE END. REMOVE FILINGS FROM INSIDE CONDUIT.
4. REINSTALL ITEMS (2), (4), AND (5) IN THAT ORDER.
5. INSTALL REASSEMBLED CONDUIT INTO (3) AND TIGHTEN (2).

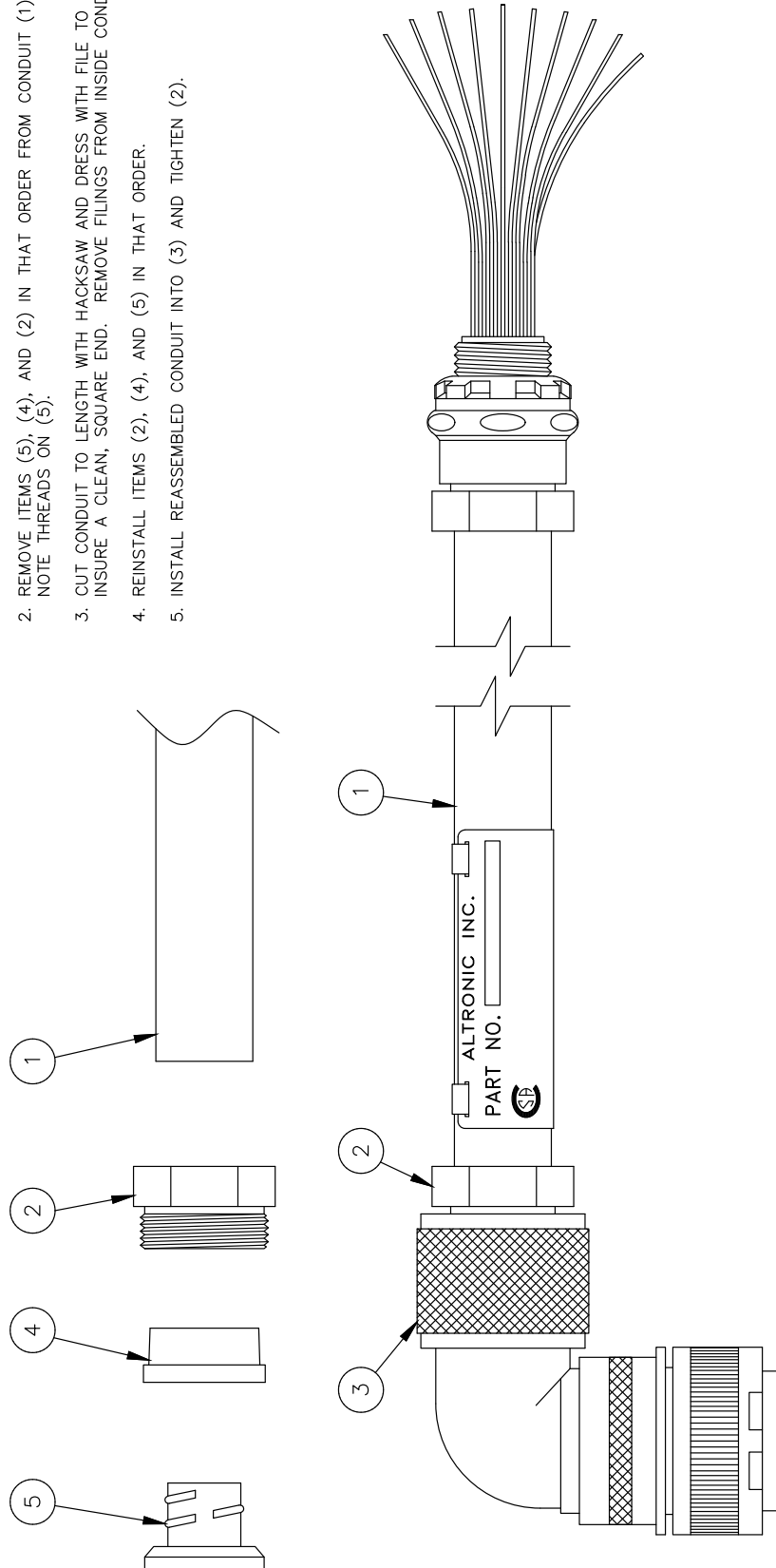
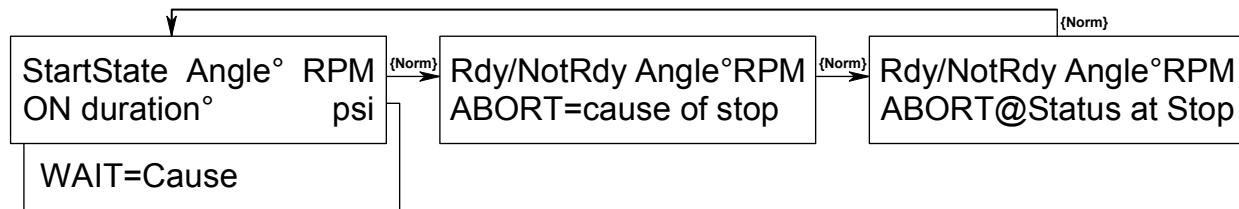

FIG. 15 – HOME SCREEN STATUS MESSAGES



Next + Setup F1
Prev - Norm F2

READY 220° 0
WAIT=DIGopen
Starter is inhibited because Digital Input is not Grounded.

TRYING 220° 0
110°@ 5° RPM
Starter is actuating outputs but engine is not yet turning.

ROLLING 35° 15
ON 110° RPM
Starter is rolling the engine below purgeRPM threshold.

PURGING 45
ON 90° RPM
Starter is rolling the engine counting purge cycles.

STARTING 50
ON 80° RPM
Starter is rolling the engine Purge is done, output is on.

FIRING 80
ON 0° RPM
Duration is at zero because Combustion has occurred.

RUNNING 195
RPM
Duration has been at zero for RunCycles, starter is off.

READY 220° 0
WAIT=AirLow 0
Starter is inhibited because Air Supply Pressure is low. Value displayed on bottom line.

NotRDY 220° 0
WAIT=RETRY 95
Starter is inhibited because of the previous start attempt. Inhibit Starter to reset.

NotRDY 220° 0
WAIT=FluxLO
Magnet is not present or Gap is Too large.
WAIT=FluxHI
Magnet is Too Strong or Gap is Too Small.
WAIT=FluxDELT
Magnet is not in proper alignment.

NotRDY 220° 0
WAIT=TblErr A
Pattern Table values are Out of Order. Initiate Table Err RPM out of Order.
Wait=TblErr I
Duration Table Err RPM out of Order.
Wait=TblErr D
Air Start, Stop, Reset are out of Order.
Wait=AirErrSS

READY 220° 0
ABORT=Powerup
ABORT@PowerUP
Abort history initialized on powerup of system.

READY 220° 0
ABORT=STARTED
ABORT@FIRING
Last start was completed when engine started.

READY 220° 0
ABORT=DIGopen
ABORT@STARTING
Start aborted when DIG input was opened while engine was starting.

NotRDY 220° 0
ABORT=AirLow
ABORT@PURGING
Termination of a start due to low Air Supply while purging the engine.

READY 220° 0
ABORT=Backward
ABORT@TRYING
Start Aborted due to backward rotation when trying to start.

View Screens

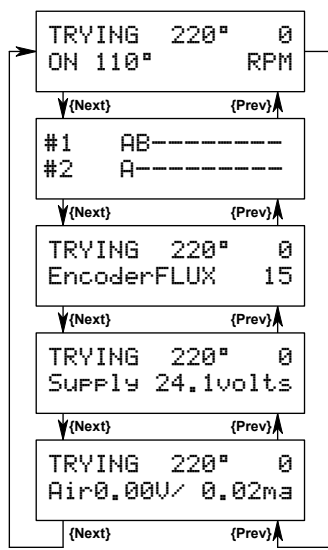
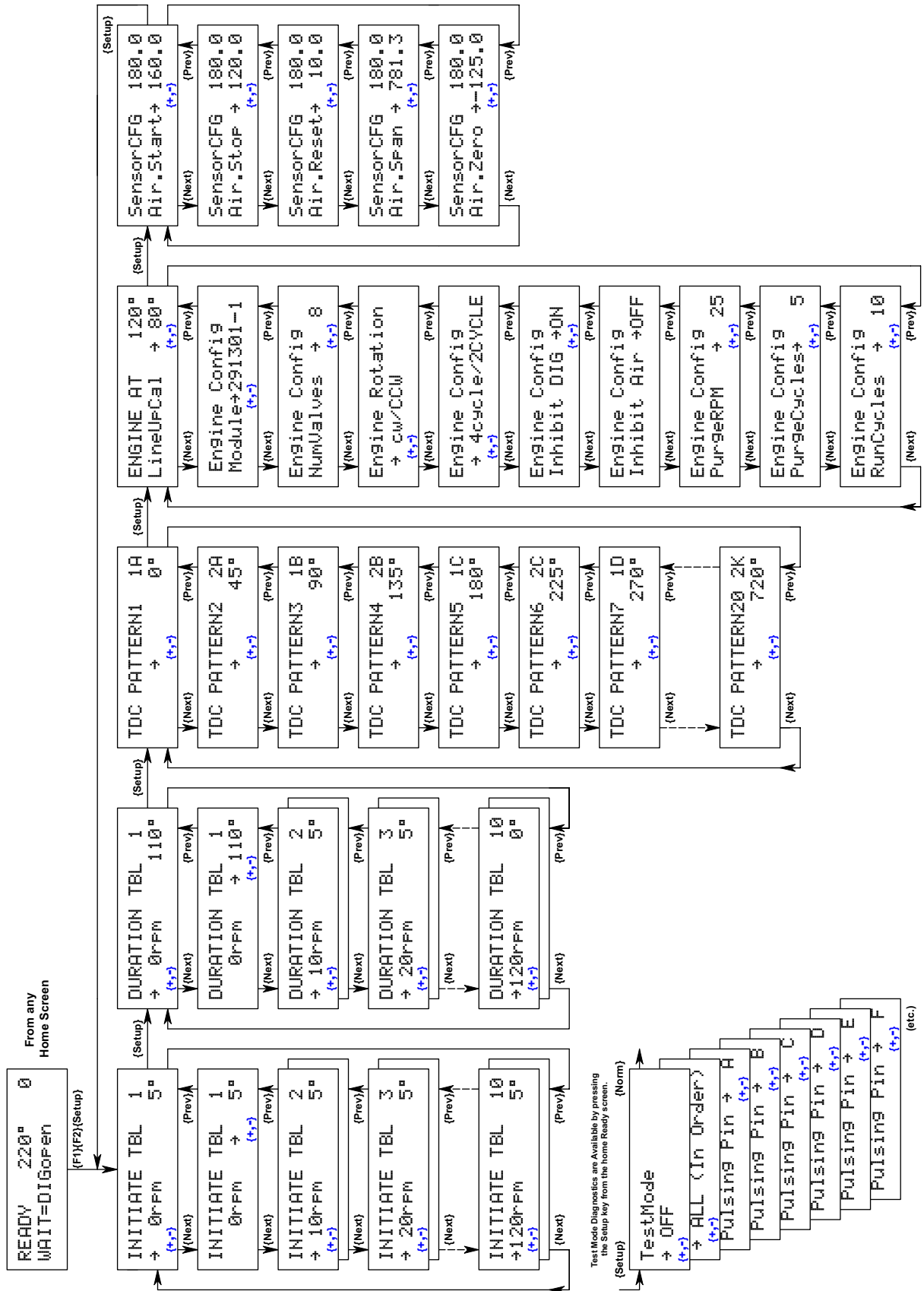

FIG. 16 – CONFIGURATION SCREENS



X
-
_
+

SaveAIR - Electronic Air Start System

Connection: ResetComStats Disconnect Chart ROI DeviceConfig Snapshot LogFile HotKeys Help Exit

ID# SaveAIR V1.6 03/29/2005 ShowColors

0 RPM

223°

flux = 23

Supply 24V

Ready

wait=DIGopen
abort=DIGopen
@Trying

#Outputs	<input type="text" value="10"/>
Module 291301 -	<input type="text" value="1"/>
LineUp	<input type="text" value="0"/>
TDC PATTERN	
#1 [A]	<input type="text" value="0"/>
#2 [B]	<input type="text" value="60"/>
#3 [C]	<input type="text" value="72"/>
#4 [D]	<input type="text" value="132"/>
#5 [E]	<input type="text" value="144"/>
#6 [F]	<input type="text" value="204"/>
#7 [G]	<input type="text" value="216"/>
#8 [H]	<input type="text" value="276"/>
#9 [J]	<input type="text" value="288"/>
#10 [K]	<input type="text" value="348"/>

Lookup Table	INITIATE
Point# RPM	<input type="text" value="5"/>
1	<input type="text" value="0"/>
2	<input type="text" value="10"/>
3	<input type="text" value="20"/>
4	<input type="text" value="30"/>
5	<input type="text" value="40"/>
6	<input type="text" value="60"/>
7	<input type="text" value="75"/>
8	<input type="text" value="100"/>
9	<input type="text" value="125"/>
10	<input type="text" value="150"/>

Lookup Table	DURATION
Point# RPM	<input type="text" value="100"/>
1	<input type="text" value="0"/>
2	<input type="text" value="10"/>
3	<input type="text" value="20"/>
4	<input type="text" value="30"/>
5	<input type="text" value="40"/>
6	<input type="text" value="60"/>
7	<input type="text" value="75"/>
8	<input type="text" value="100"/>
9	<input type="text" value="125"/>
10	<input type="text" value="150"/>

<input type="checkbox"/> Clockwise Rotation	ASP Start	<input type="text" value="160.0"/>
<input type="checkbox"/> 4 Stroke (720°)	ASP Stop	<input type="text" value="120.0"/>
<input checked="" type="checkbox"/> Inhibit by Digital Input	ASP Rst	<input type="text" value="10.0"/>
<input type="checkbox"/> Inhibit by Supply Pressure	Purge RPM	<input type="text" value="25"/>
Purge Cycles	Purge Cycles	<input type="text" value="5"/>
Run Cycles	Run Cycles	<input type="text" value="10"/>

ASP Start	<input type="text" value="160.0"/>
ASP Stop	<input type="text" value="120.0"/>
ASP Rst	<input type="text" value="10.0"/>
ASP Slope	<input type="text" value="-124.3 PSI"/>
ASP Offset	<input type="text" value="781.3"/>
ASP Offset	<input type="text" value="-125.0"/>

COM1: 9600,n,8,1:Communicating Polls:29 Errs:0