

TITLE: DN80 GAS TRAIN
DRAWING NO: GGT0080B

IT	DESCRIPTION	DWG NO.	QTY
1	GAS FILTER, FLANGED, DN80	GFL003	1
2	ZERO PRESSURE REGULATOR, FLANGED, DN80	GGR007	1
3	DUAL SOLENOID VALVE, FLANGED, DN80	GSV006	1
4	SEAL, DN80	G12021	4
5	HARDWARE KIT, DN80	G11002	24
6	REGULATED OUTPUT PRESSURE SWITCH	G11012	1
7	FLANGE ADAPTER, DN80	G11008	1

TITLE: PLENUM BODY, 9" W/ DIFFUSER PLATE
DRAWING NO: GPV0009-KT

IT	DESCRIPTION	DWG NO.	QTY
8	PLENUM, 9" OD	G9001	1
9	PLENUM BAFFLE	G9002	1
10	HARDWARE KIT	G9003	1

TITLE: END CAP, DN80, 9" PLENUM
DRAWING NO: G90080

IT	DESCRIPTION	DWG NO.	QTY
11	PLENUM, PLATE 9"	615 430	1
12	BOLT, M16 X 60M	902 784	8
13	LOCKWASHER, M16	902 789	8
14	WASHER, SEAL, M6	902 790	8
15	NUT, M6	902 786	8

TITLE: PLENUM OUTLET PLATE, 9"
DRAWING NO: G9420

IT	DESCRIPTION	DWG NO.	QTY
16	PLENUM OUTLET PLATE, 9"	G9420	1

NOTE:
ALL DIMENSIONS ARE IN INCHES UNLESS SPECIFIED

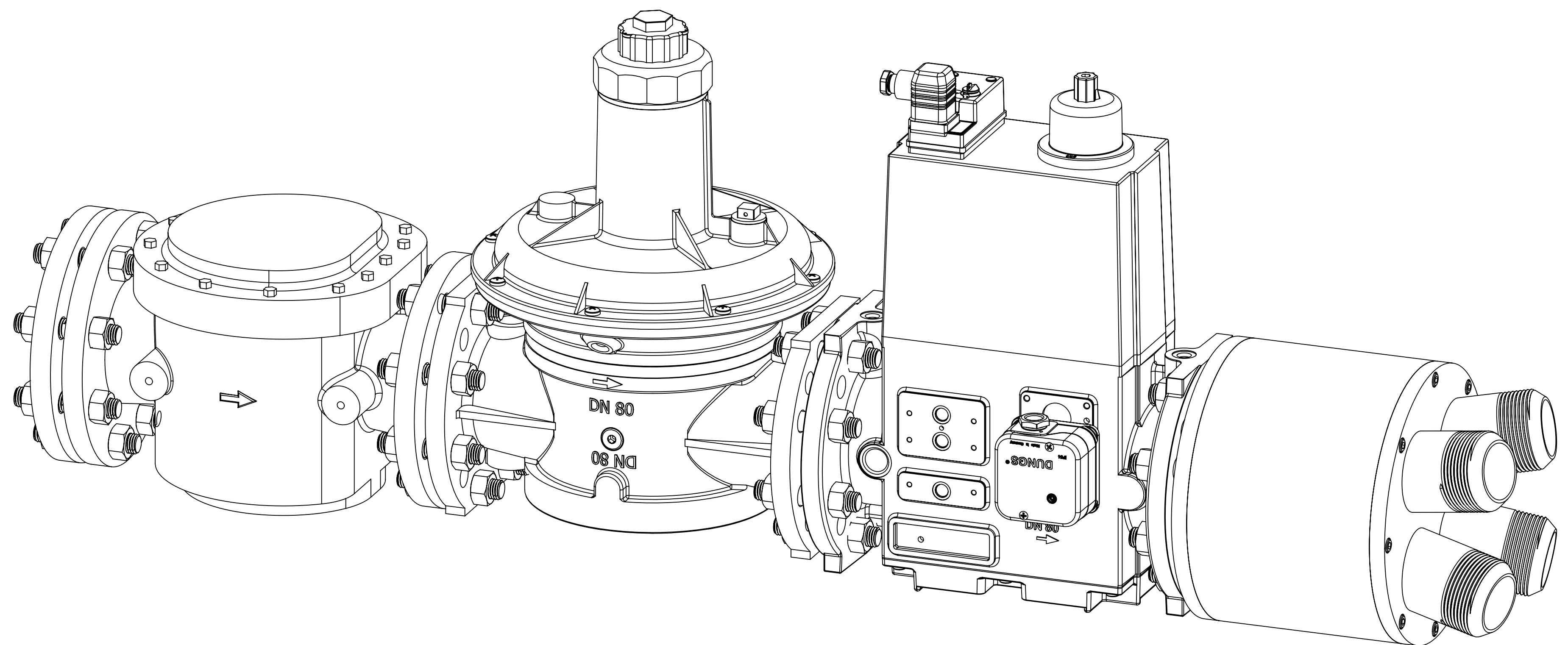

REVISIONS				TOLERANCES (EXCEPT AS NOTED)	Altronic	Drawn in Solidworks
REV	DATE	BY	DESCRIPTION			

CONFIDENTIAL - Copyright Altronic, LLC All rights reserved. May not be copied in whole or in part without prior written permission from Altronic, LLC.				DECIMAL: .xxx = ±.005 .xx = ±.010	TITLE GGT0080B + PLENUM ASSEMBLY 4 OUTLET	
DRAWN BY	NML	DATE	12-14-15	DRAWING NUMBER	SK2179	
CHECKED BY		DATE				
APPROVED BY		DATE				